

Franklin Computer

2128 ROUTE 38
CHERRY HILL, NEW JERSEY 08002
609 482-5900 • TELEX 837-385

DATE: March 22, 1984

TO: Authorized Service Centers

FROM: P. F. Santore
Manager, Technical Services

SUBJECT: Technical Reference Manual Update

Enclosed are new additions for your Technical Reference Manual and a special parts offer for the new MPI Drive and Rev. A Motherboard (P/N 1100019-01). Also included is a new Table of Contents which includes the new additions.

The new additions cover the Rev. A Motherboard, which was introduced in the Family Pack, the MPI Disk Drive, the Franklin Video Monitor, and a Troubleshooting Guide.

The documents on the Rev. A Motherboard, Disk Drive and Monitor have been developed using a new format for the Technical Reference Manual. Each new section has been written as a stand alone booklet using a standard format to aid in locating information quickly and easily.

CHANGE	LOCATION
1. TABLE OF CONTENTS	TABLE OF CONTENTS
	ADDITIONS
2. MOTHERBOARD REV. A	SECTION 13
3. DISK DRIVE - MPI	SECTION 14
4. FRANKLIN MONITOR	SECTION 15
5. TROUBLESHOOTING GUIDE	SECTION 19

Computer

1984

DATE: 1984

TO: Authorized Service Centers

FROM: P. E. Sanders
Manager, Technical Services

SUBJECT: Technical Reference Manual Update

The new additions for your Technical Reference Manual
are included for the new MII Drive and Monitor
and the new MII Drive. Also included is a new Table
of Contents. Under the new additions.

For the Rev. A Motherboard, which was
back the MII Drive, the Table
of Contents.

Rev. A Motherboard, Disk Drive and Monitor
using a new format for the Table
of Contents. Each new section has been written as a
standalone format to aid in locating
information and easily.

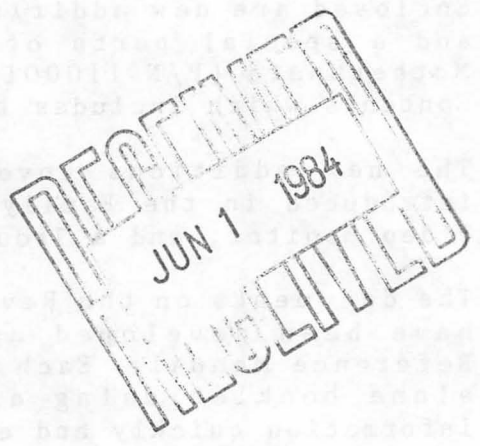

LOCATION	DESCRIPTION
SECTION 1	TABLE OF CONTENTS
SECTION 2	ADDITIONS
SECTION 3	REV. A MOTHERBOARD
SECTION 4	DISK DRIVE - MII
SECTION 5	TEXTILE MONITOR
SECTION 6	TECHNICAL REFERENCE GUIDE

FRANKLIN COMPUTER CORPORATION
1070 BUSCH MEMORIAL HIGHWAY
PENNSUAKEN, N. J. 08110

(609) 488-0600

DEALER SERVICE MANUAL

TABLE OF CONTENTS

SECTION 1 - GENERAL INFORMATION

GEN-001.1 FCC Service Center

SECTION 2 - PROCEDURES

PRO-001.1 Warranty Service Report

PRO-002.1 Parts Order Procedure

PRO-003.1 Defective Material Tag

PRO-004.1 Parts Return Procedure

SECTION 3 - WARRANTY REPAIR

WAR-001.1 Warranty Policies and Procedures

SECTION 4 - NON WARRANTY REPAIR

NWA-001.1 Non-Warranty Policies and Procedures

SECTION 5 - SERVICE CENTER INVENTORY

INV-001 Service Center Inventory Requirement

INV-002.1 ACE Computer Parts Kit

INV-003.1 Floppy Disk Subsystem Parts Kit

INV-004 Franklin Peripheral Cards

SECTION 6 - DEALER PARTS LIST

DPA-001.1 ACE Computer Dealer Parts List

SECTION 7 - RETAIL PARTS LIST

RPA-001.1 ACE Computer Retail Parts List

SECTION 8 - ACE 100/1000/1200 TECHNICAL INFORMATION BULLETINS

ACI-001 EPROM Revision Levels

ACI-002 FRANKLIN/APPLE Keyboard Differences

ACI-003 I.C. Specification for Motherboard

ACI-004 230V, 50HZ Conversion

ACI-005 I.C. Specification for Colorboard

ACI-006 Dual I/O Interfacing

ACI-007 Keyboard

SECTION 9 - ACE COMPUTER DIAGNOSTICS

SECTION 10 - DISK SUBSYSTEM THEORY OF OPERATION

SECTION 11 - DISK SUBSYSTEM TECHNICAL INFORMATION BULLETINS

DSK-001 Floppy Disk Analog Modification
DSK-002.1 ACE 10 Subsystem Alignment Procedures

SECTION 12 - SOFTWARE TECHNICAL INFORMATION BULLETINS

SOF-001 AppleWriter Modification
SOF-002 MUSE Supertext Modification

SECTION 13 - REV. A MOTHERBOARD P/N 1100019-01

SECTION 14 - DISK DRIVE - MPI

SECTION 15 - FRANKLIN MONITOR

SECTION 16 -

SECTION 17 -

SECTION 18 -

SECTION 19 - TROUBLESHOOTING INFORMATION

TBS-001 TROUBLESHOOTING GUIDE - QUICK REFERENCE

MOTHERBOARD REV A

P/N 1100019—01

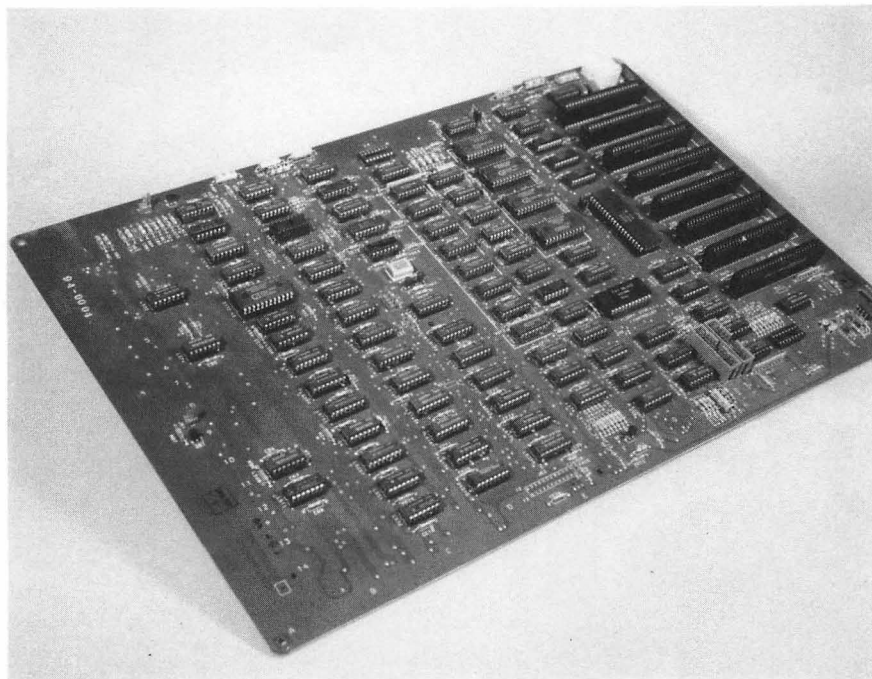

TABLE OF CONTENTS

GENERAL INFORMATION	1-1
SPECIFICATIONS	2-1
INSTALLATIONS	3-1
THEORY OF OPERATIONS	4-1
MAINTENANCE	6-1
PARTS LIST	7-1

GENERAL INFORMATION

The Franklin motherboard, P/N 1100019-01, REV A, contains all of the basic circuitry to provide the user with both a black and white and full color system with 64K of memory, an auto start basic interpreter and a two drive disk controller. When placed into an ACE 1000, 1100 or 1200 with the standard 72-key keyboard, 50 watt power supply and monitor a very powerful and versatile system exists.

Options from Franklin and/or a variety of O.E.M. companies allow you to expand the system to include combinations of equipment up to a total of six floppy disk drives, a hard disk, 80-column capability, a Z80 micro processor for CP/M compatibility, serial or parallel printers, expanded memory and joysticks for games.

Most of these options require only an additional circuit board that is plugged into one of the available I/O slots located on the rear of the board, marked J0 through J7. Not all of the equipment mentioned above can be installed at the same time due to system configuration limitations.

NOTE: In the board's present arrangement slot J6 is not available for external circuit cards.

Figure 1-1 shows a basic configuration of the expansion boards available to an ACE system.



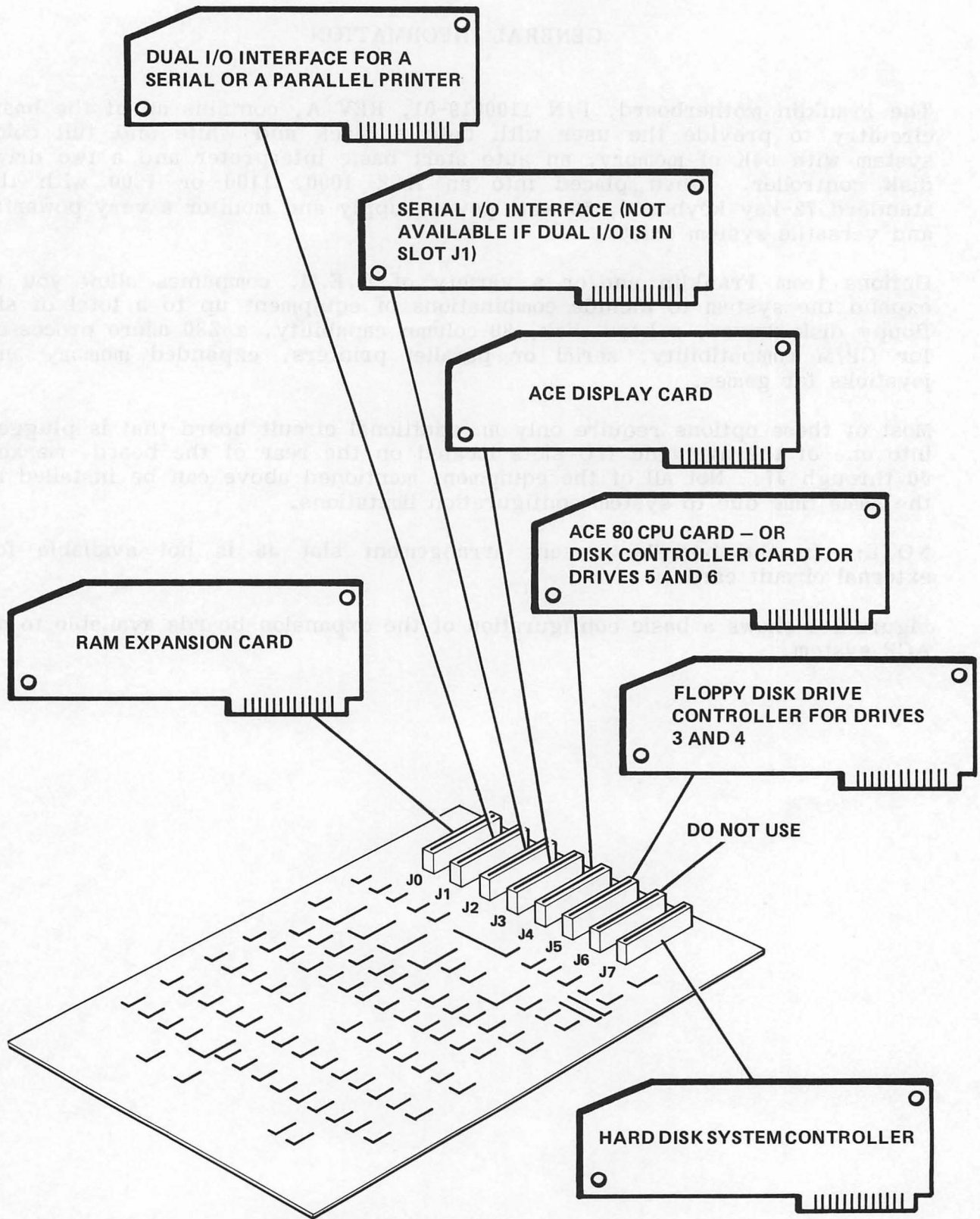
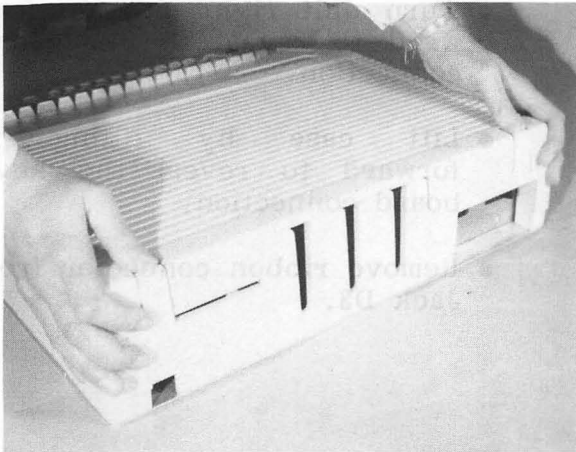

Figure 1-1. Suggested Placement of OEM Peripheral Cards.

SPECIFICATIONS

Microprocessor	6502 operating at 1.02 Mhz
Text	40 characters per line by 24 lines 5X7 dot uppercase characters 5X7 dot lowercase characters Normal, inverse and flashing characters Full cursor controlled-protected screen feature
High Resolution Graphics	280 Horz X 192 Vert pixels 280 Horz X 160 Vert with 4 lines of text
Memory	64K RAM 250 NSEC Access time 3 sockets for eproms
Physical	17 3/8" deep X 11 1/2" wide
Power Required	115 Vac, 60 Hz, 50 watts
Master Clock	14.31818 Mhz.
Color Resolution	16 colors Lo Res 6 colors Hi Res

INSTALLATION



STEP 1

- Remove power cable.
- Place thumbs in slots, applying slight outward pressure while lifting cover with fingers.
- Raise cover by pulling it forward.



STEP 2

- Check for and remove all peripheral circuit cards in slots J0 through J7.
- Remove monitor cable.
- Remove floppy disk drive cables.
- Remove game I/O cables if necessary.

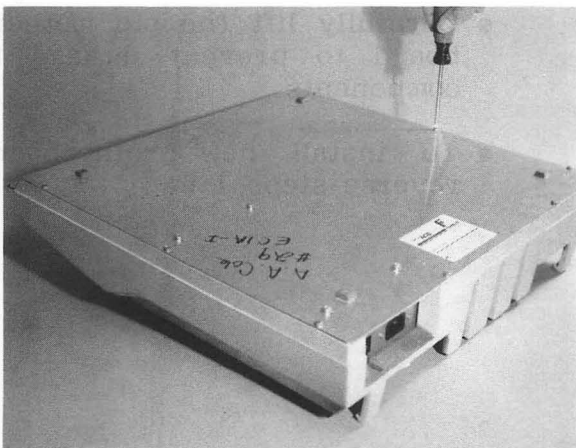

STEP 3

- Turn unit upside down being careful not to damage keyboard.
- Remove the 11 screws (shown in circles) from base plate.

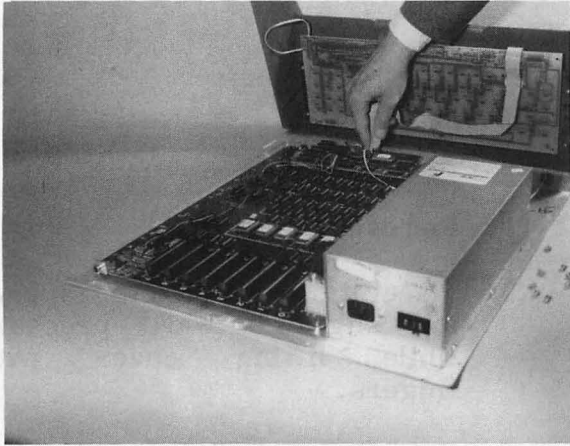

STEP 4

- Turn unit right side up forward to reveal the keyboard connection.
- Lift case by tilting it forward to reveal the keyboard connection.
- Remove ribbon connector from Jack D3.

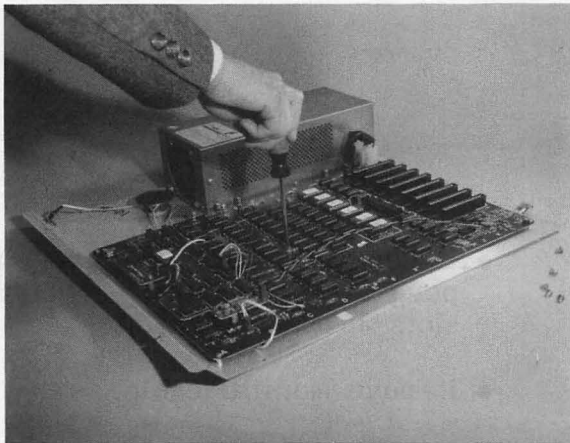

STEP 5

- Using a phillips head screwdriver, remove the 10 screws that hold the motherboard to the base plate.
- Remove the power supply, speaker and reset switch cables.

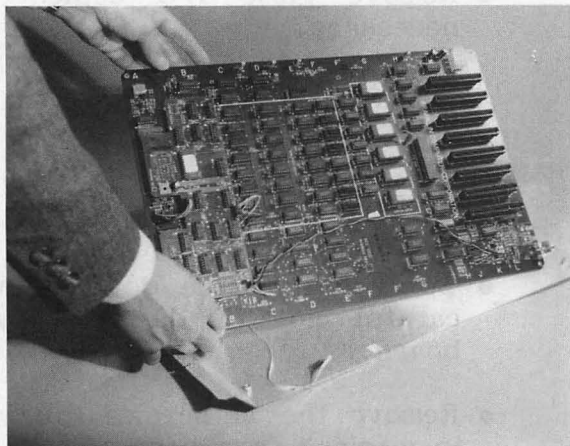

STEP 6

- Carefully lift the old motherboard to prevent damage to components.
- To install new motherboard reverse steps 1-6.

THEORY OF OPERATION

When power is applied to an ACE 1000 series unit the following sequence of events will take place. These events will happen in a span of time less than one second. After you have seen these events happen correctly a few times, you will be able to "sense" when the machine has a malfunction.

To begin, you should have your monitor connected and powered on for a few seconds before you turn on the power supply switch. The first thing that you should see is a full screen of characters. This page of characters will often differ between units. However, the characters will most often be a full page of inverse "AT" signs (@) because they have a HEX code of "00." The screen pattern is a result of the RAM being cleared out to make room for the system's resident routines to initialize.

Next, the speaker will emit a single "beep" as location \$C030 is cleared. This beep will be followed immediately by the screen being cleared. This step ends the housekeeping phase. The next phase is the auto boot ROM (H2) bringing the unit into its normal operation. The first visible step will be the writing on the screen of

ACE 1000 v2.2
or
ACE 1200 v2.3

depending on which unit you are testing. The system will then search through each I/O slot for a disk controller card starting at J7 and going to J0.

-- If a disk controller card is found the system will initiate a "read" operation until a disk is located or the operator pushes the RESET switch under the keyboard. RESET will bring up FPBASIC with the prompt (]) on the lower left of the screen.

-- If no disk controller is found the unit goes directly to FPBASIC as noted above.

If all of the above events happen to your unit, then your machine is probably operating normally unless you already know otherwise.

The following is a brief description of how each major circuit functions. In the event your unit does not work and you suspect that the motherboard is at fault, you can use the information below in guiding you to troubleshoot the board. Whenever possible, the IC "chips" are given names based on their functions in the circuit. Reference will be made to the location of the IC by the letter/number matrix designation (e.g. Floppy disk controller [H10]; column H, row 10). A few "chips" made up of OR gates or AND gates may be used by several circuits making it difficult to designate. However, once you isolate the problem to a specific area, finding the right component

becomes easier. When you read each circuit description, you should follow along with your BLOCK DIAGRAM at the end of this section. This will increase your understanding of the circuit relationships.

POWER ON RESET

When the switch at the rear of the power supply is turned to the ON position voltages of +5, -5, +12, and -12 VDC are generated and fed to the motherboard through the 6 PIN connector near the coordinate L-1. A single trigger is generated by "chip" C1-B that is sent to the keyboard connector (D3), disk motor controller (H14), 6502 CPU (J8) and the I/O connectors J0 through J7. The 75 MSEC trigger out of H14 is not used since it occurs while the line is already pulled low.

TIMING AND CONTROL

The timing and control circuit goes active as soon as power is applied to the motherboard and remains active until power is removed. All timing signals originate with the 14.31818 Mhz crystal (E6) and the two transistors QE1 and QE2. Through E5, PIN 8, the signal MCLK, for master clock, is generated. This is the base for all other signals shown in TABLE 4-1. Circuit components E2, E3, and E4 act as step down counters that produce signals used by almost every IC on the board and are accessible by J0 through J7 to any peripheral card connected.

TABLE 4-1

FREQUENCY	DESIGNATION	CIRCUIT USE
14.31818 Mhz	MCKL	VIDEO OUTPUT
7.159 Mhz	COB1, COB1 (L)	CHARACTER GENERATOR
3.58 Mhz	COB2, COB2, (L)	COLOR BURST SIGNAL
2.0 Mhz	2Mhz, 2Mhz (L), CAS (L), R/CAS, RAS (L)	USED THROUGH-OUT SYSTEM
1.0 Mhz	1Mhz, 1Mhz (L), 2KC0, 2KC8	USED THROUGH-OUT SYSTEM

DATA BUS

The Data Bus is eight lines used to parallel transfer a single byte of information throughout the system. Since the Bus is shared by memory, the CPU and all I/O device timing is critical. (Data is input to the Bus from these areas through various gate circuits.) The list below identifies those IC's by location.

<u>FROM</u>	<u>VIA</u>
KEYBOARD	D4, D7
FLOPPY DISK CONTROLLER CARD	H7, H10
6502 CPU	J10, J11
EPROMS	DIRECTLY FROM H2, H4, H5
I/O CONNECTORS	DIRECTLY FROM PINS 42 THROUGH 49
RAM MEMORY	D4, D5, D6, D7

Data on the Bus is available to all circuits that have output capability. The CPU and the timing network activate whatever circuit requested the data. The following list shows the path the information will follow after leaving the BUS.

<u>TO</u>	<u>VIA</u>
I/O CONNECTORS	DIRECTLY ON PINS 42 THRU 49
6502 CPU	J10, J11 TRANSCEIVERS
FLOPPY DISK CONTROLLER	H10 GATE ARRAY
VIDEO MONITOR	RAM MEMORY

VIDEO DISPLAY

Information for display as text or graphics in monochrome or color will follow basically the same path. The data originates in RAM where specific locations have been reserved for two pages of 960 character positions (40 char X 24 lines). Information is gated out of RAM (F3 through F10) to the latches (D5, D6) to the color/text dot generator (C5). Here the Hex coded byte is converted into a bit stream that will eventually be "painted" on the CRT by the scan lines.

Outputs from C5, along with the inverse signal from B11, are gated (C6, C7) into a storage register (C8, C9). The next LDTG timing pulse transfers the data to two multiplexers (C10, D8) whose output is stored briefly at C4 to await transfer to video phase modular prom (D14) and a storage register (E13). The combined outputs of D14 and E13 are fed to the RGB interface connector space (JE2) and to the multiplexer (E14). Output from E14 goes through QF1 to the Aux Video and video output jacks.

Flashing characters are created by a trigger from C1-A through an AND gate (G5, PIN 11) and an OR gate (B4, PIN 4) fed into the inverse circuit (C4).

Sync circuits, timing signals and control signals are numerous within the video section. The list below gives you the IC locations for most of these AND gates, OR gates and Flip/Flops.

<u>COLUMN</u>	<u>ROW</u>
B	4, 11, 12
C	2, 7, 13
D	2
F	11, 12, 13
G	5, 7, 10, 11, 12, 13

ADDRESS BUS

The address bus, listed as MAR for Memory Address Register, is a network of 16 lines that is similar to the Data Bus in that it is throughout the motherboard and accessible from a variety of circuits. One significant difference is that all addresses, or all information on the MAR, originates at the 6502 CPU and is put on the Bus by the address transmitters (J3, J4, J5). The circuits that can input addresses from the MAR are listed below with IC coordinates of the circuits through which the information travels.

<u>TO</u>	<u>VIA</u>
FLOPPY DISK CONTROLLER	DIRECTLY TO H10, H7
EPROM SELECT	H1, H8
EPROMS	DIRECTLY TO H2, H4, H5
KEYBOARD & SPEAKER	H9
I/O CONNECTORS J0 THROUGH J7	DIRECTLY TO PINS 2-17
I/O SELECT	J12
DEVICE SELECT	J2
GAME I/O	J14
TEXT & GRAPHICS SELECT	G14
RAM	E9, 10, 11, 12, F2

Not all the circuits noted in the list above use all 16 bits of the MAR. Often only a portion of the address is relevant. In those cases only the 2 or 3 bits needed will be inputted (e.g. the device enable circuit (J2) only uses MAR 4/5/6/7).

FLOPPY DISK CONTROLLER

This circuit consists of the "ACE FDC" or "Gate-Array", at H10; stepper motor speed controller, drive enable, select and read/write controller, at H12; the eprom, at H7; and the AND gate, at H13. Data is read from and written to the data bus directly by the gate array and transmitted in several fashions to and from the drives via JH3 and JJ1. Address information on where the data is located on the disk is decoded by H12. This then turns on the selected drive and activates the drive motor and read/write head assembly. The eprom of H7 contains a 250 byte data code that controls the gate array. If a disk controller card is used in slot 6, this circuit must be disabled.

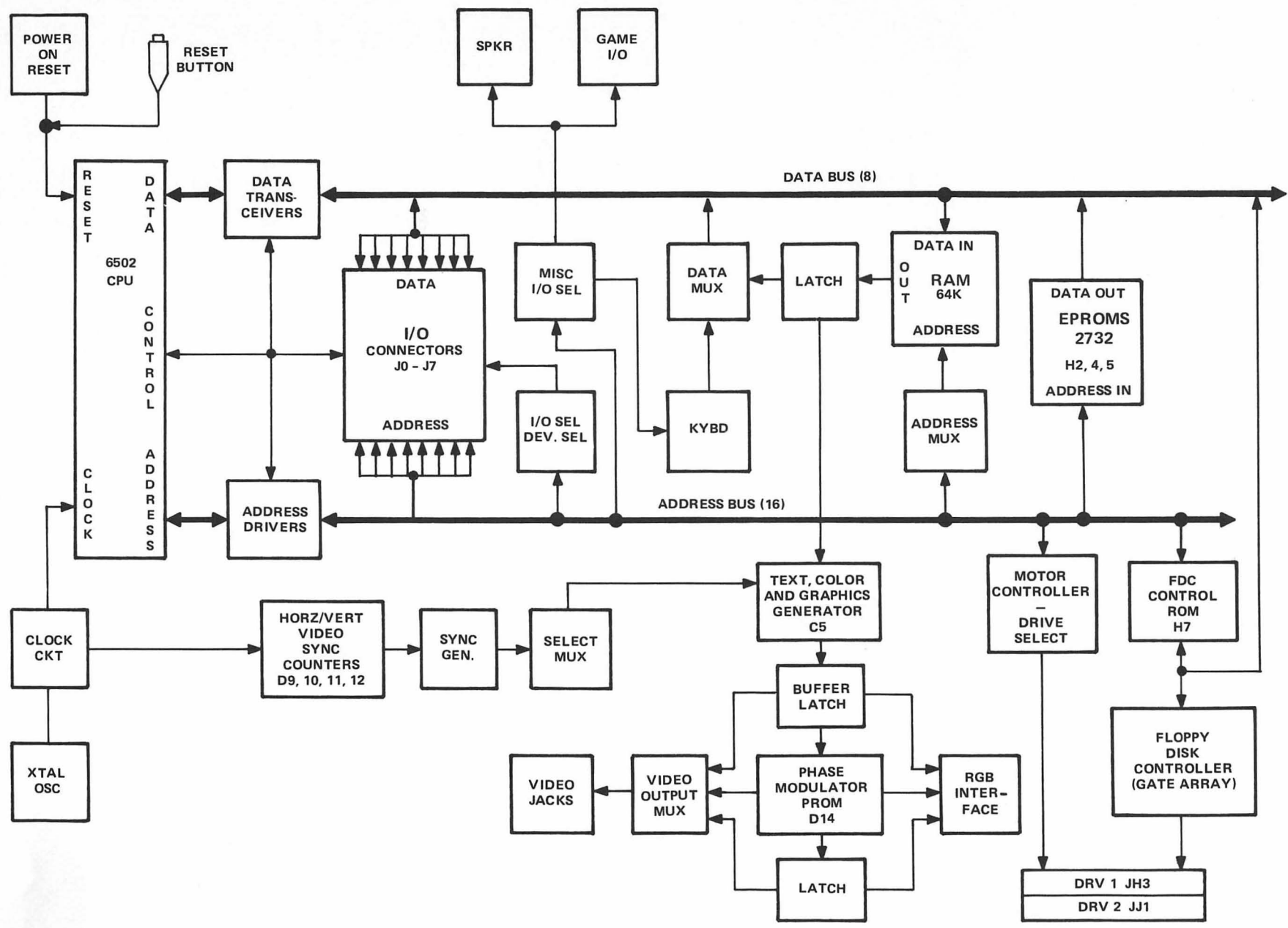

4-5

ACE 1000/1200 Motherboard P/N 1100019-01 Rev A

MAINTENANCE

IC IDENTIFICATION CHART

CONNECTOR AND CONFIGURATION OPTIONS

LOGIC DIAGRAMS -- 4 PAGES

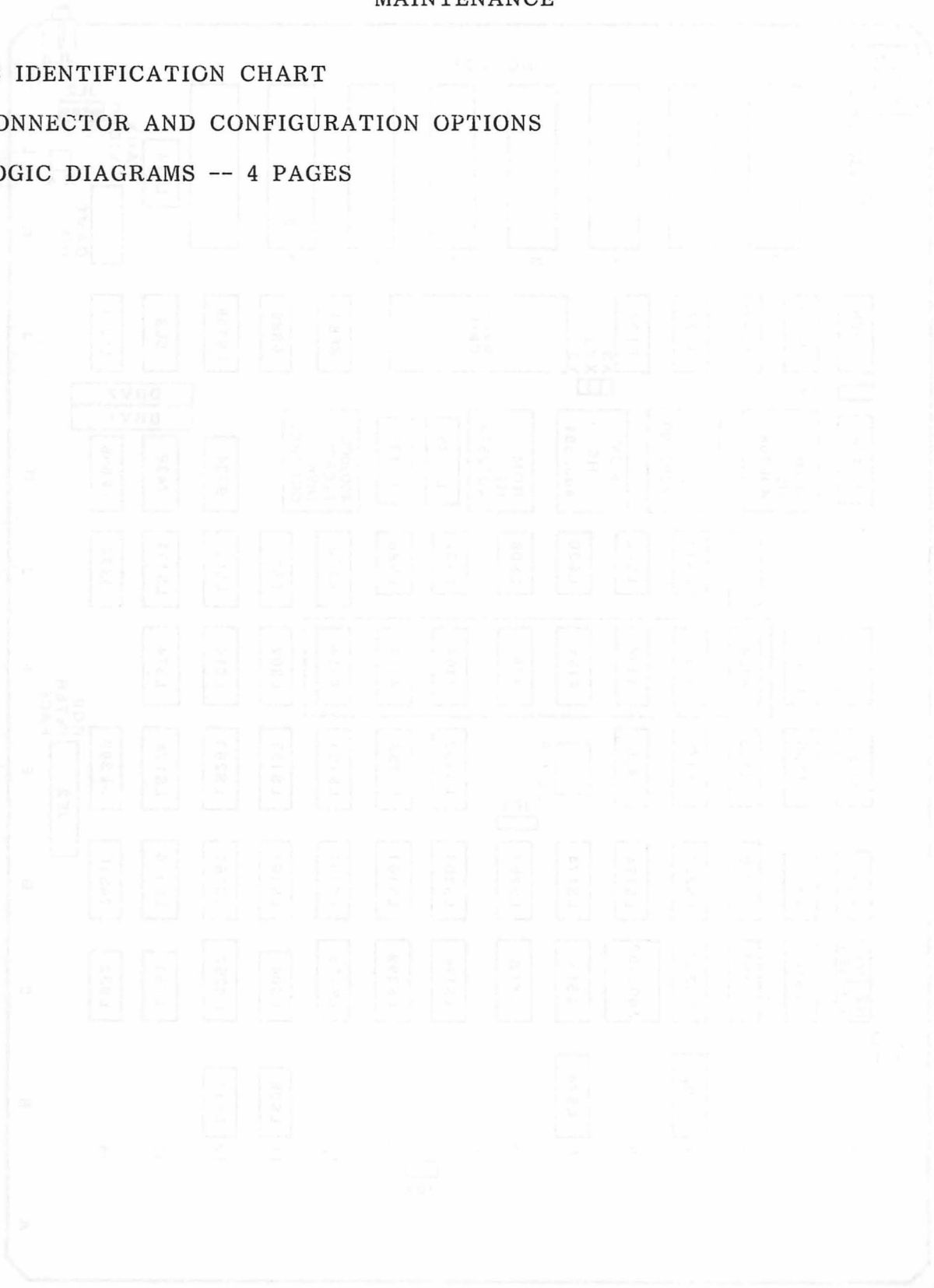

LOCATION OF CONNECTORS AND CONFIGURATION OPTIONS ON THE ACE MOTHERBOARD

- JB1: RESET SWITCH INPUT
- JC1: SPEAKER OUTPUT
- D3: KEYBOARD CONNECTOR
- JE1: AUXILIARY TIMING OUTPUT
- JE2: RGB INTERFACE
- G2: WG1 - WG8; MEMORY CONFIGURATION JUMPERS

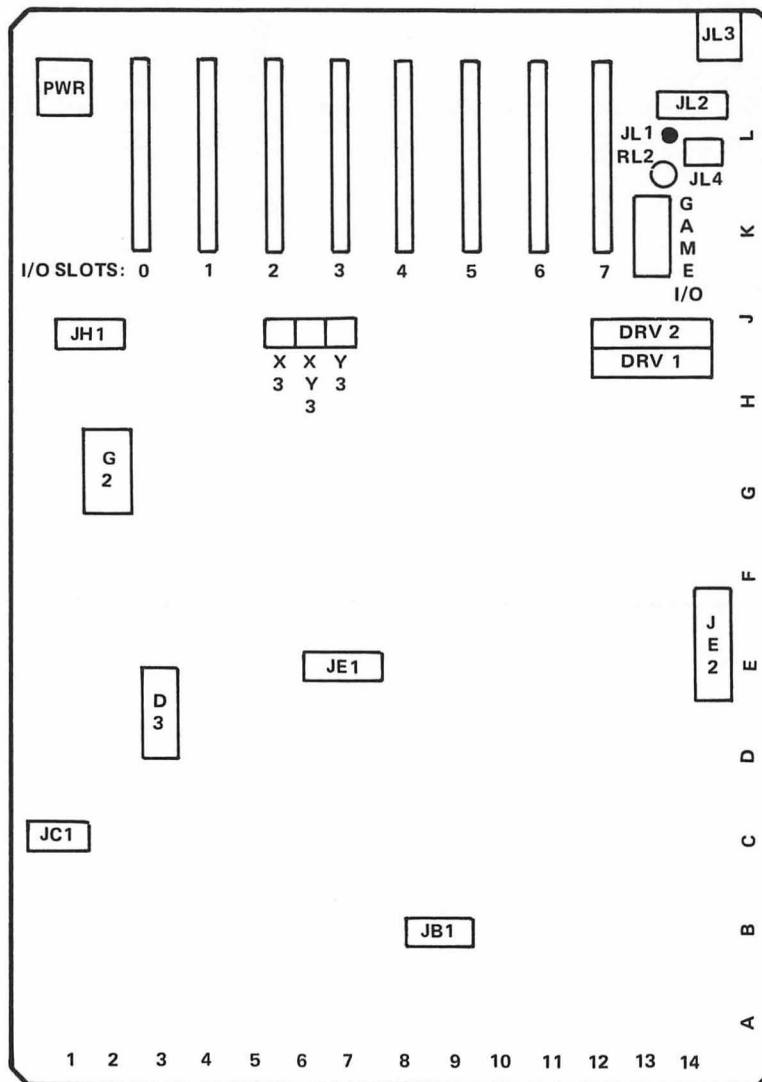

- JH1: 13 & 16 SECTOR JUMPER
- X3,XY3,Y3: MOVE JUMPER FROM X3, XY3 TO XY3, Y3 TO DISABLE ON BOARD RAM > BFFF
- DRV1: FLOPPY DISK CONNECTOR FOR DRIVE #1
- DRV2: FLOPPY DISK CONNECTOR FOR DRIVE #2
- JL1, JL2, JL4: AUXILIARY VIDEO OUTPUTS
- JL3: VIDEO OUTPUT
- RL2: VIDEO OUTPUT SIGNAL (JL3) TRIMMER POT

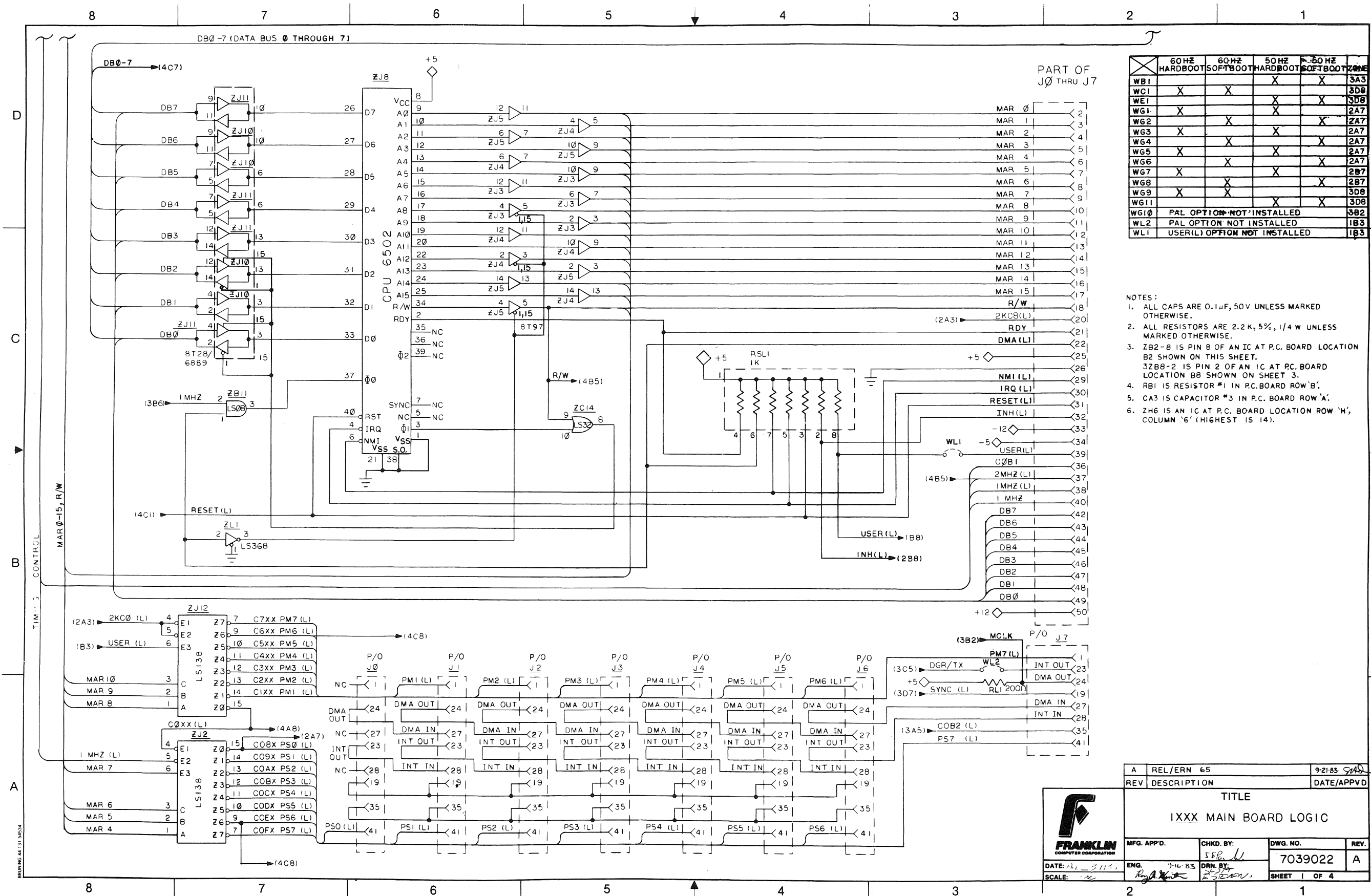

	60HZ HARDBOOT	60HZ SOFTBOOT	50HZ HARDBOOT	50HZ SOFTBOOT	ZONE
WB1				X	3A3
WC1	X	X			3D8
WE1			X	X	3D8
WG1	X		X		2A7
WG2		X		X	2A7
WG3	X		X		2A7
WG4		X		X	2A7
WG5	X		X		2A7
WG6		X		X	2A7
WG7	X		X		2B7
WG8		X		X	2B7
WG9	X	X			3D8
WG11			X	X	3D8
WG10	PAL OPTION NOT INSTALLED				3B2
WL2	PAL OPTION NOT INSTALLED				1B3
WL1	USER(L) OPTION NOT INSTALLED				1B3

- NOTES:
- ALL CAPS ARE 0.1µF, 50V UNLESS MARKED OTHERWISE.
 - ALL RESISTORS ARE 2.2K, 5%, 1/4 W UNLESS MARKED OTHERWISE.
 - ZB2-8 IS PIN 8 OF AN IC AT P.C. BOARD LOCATION B2 SHOWN ON THIS SHEET. 3ZB8-2 IS PIN 2 OF AN IC AT P.C. BOARD LOCATION B8 SHOWN ON SHEET 3.
 - RBI IS RESISTOR #1 IN P.C. BOARD ROW 'B'.
 - CA3 IS CAPACITOR #3 IN P.C. BOARD ROW 'A'.
 - ZH6 IS AN IC AT P.C. BOARD LOCATION ROW 'H', COLUMN '6' (HIGHEST IS 14).

A	REL/ERN 65	9-21-85	5/10
REV	DESCRIPTION	DATE/APP'D	
TITLE			
IXXX MAIN BOARD LOGIC			
MFG. APP'D.	CHKD. BY:	DWG. NO.	REV.
DATE: 11-3-83	ENG. 9-16-83	7039022	A
SCALE: 1/1	DRN. BY: E. STEVEN	SHEET 1 OF 4	

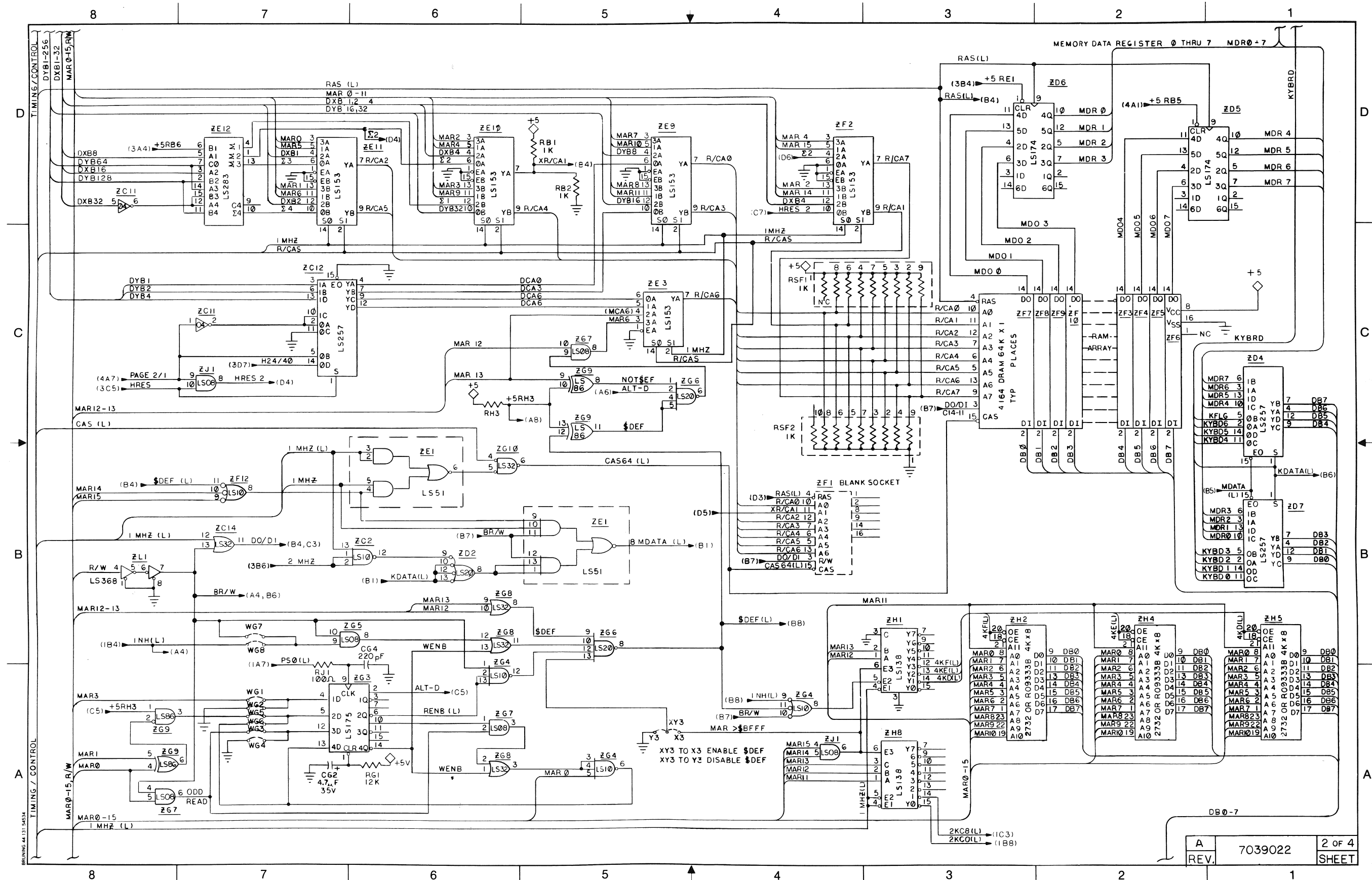

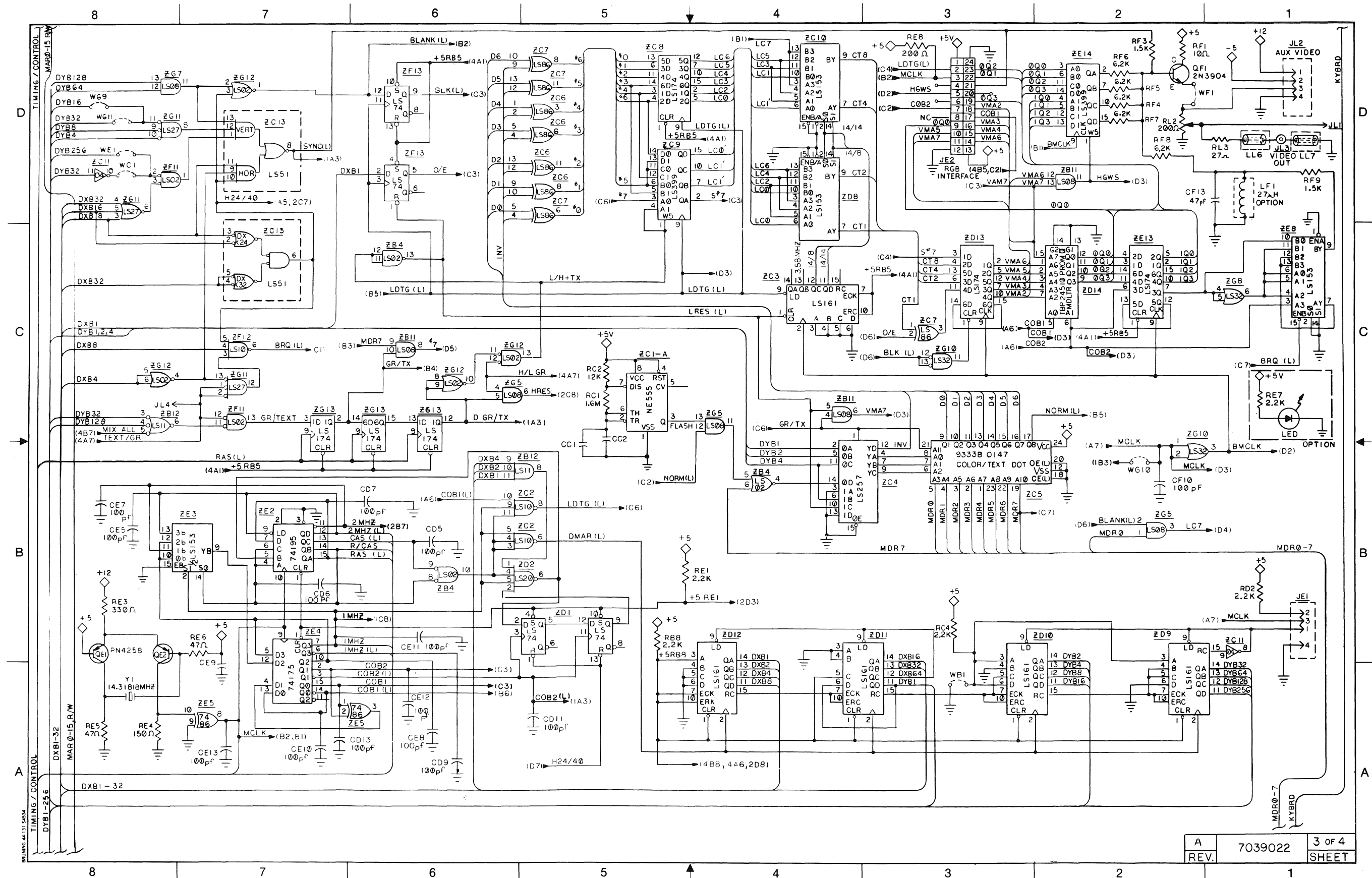

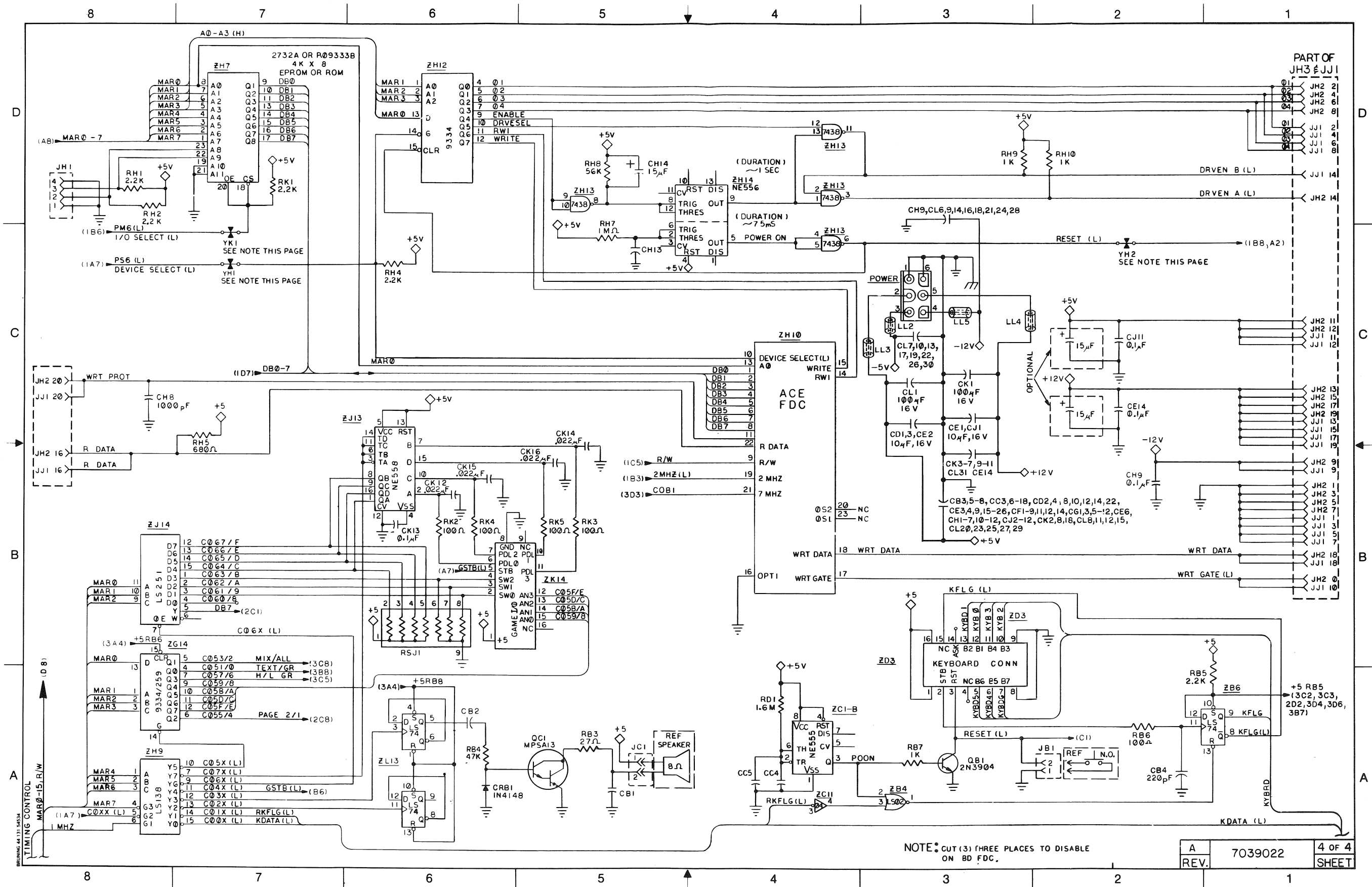

NOTE: CUT (3) THREE PLACES TO DISABLE ON BD FDC.

A	7039022	4 OF 4
REV.		SHEET

PARTS LIST

MOTHER BOARD

P/N 1100019-01 REV A

PART NUMBER	REV	QTY	DESCRIPTION	
1100019-01	A	1	PCB ASY, MAIN BOARD, 1XXX	
1. 1331428P11	A	1	PROG'D PROM, COLOR 256x4	ZD14
2. 4000035	...	1	RES, 330ohm 1/4W 5% .50	RE3
3. 4000036	...	1	RES, 10ohm 1/4W 5% .50	RF1
4. 4000037	...	2	RES, 27ohm 1/4W 5% .50	RB3, RL3
5. 4000038	...	2	RES, 47ohm 1/4W 5% .50	RE5, RE6
6. 4000039	...	6	RES, 100ohm 1/4W 5% .50	RB6, RK2-5, RJ1
7. 4000040	...	1	RES, 150ohm 1/4W 5% .50	RE4
8. 4000041	...	6	RES, 1K 1/4W 5% .50	RB1, RB2, RB7, RD3 RH9,10
9. 4000042	...	2	RES, 1.5K 1/4W 5% .50	RF3, RF9
10. 4000045	...	2	RES, 12K 1/4W 5% .50	RC2, RG1
11. 4000046	...	1	RES, 47K 1/4W 5% .50	RB4
12. 4000047	...	1	RES, 1M 1/4W 5% .50	RH7
13. 4000050	...	10	RES, 2.2K 1/4W 5% .50	RB5,8, RC4, RD2, RE1, RH1-4, RK1
14. 4000061	...	1	RES, 680ohm 1/4W 5% .50	RH5
15. 4000064	...	2	RES, 200ohm 1/4W 5% .50	RE8, RL1
16. 4000066	...	5	RES, 6.2K 1/4W 5% .50	RF4-8
17. 4000067	...	1	RES, 56K 1/4W 5% .50	RH8
18. 4000069	...	8	RES, 0ohm 0W .50	WC1, WF1, WG9 WG1, 3, 5, 7
19. 4000099	...	2	RES, 1.6M 1/4W 5% T&R	RC1, RD1
20. 4001006	...	1	POT, 200ohm	RL2
21. 4001508	...	2	CAP, 100uf 16V AL EL AXL	CK1, CL1
22. 4001548	..	2	CAP, 220pf 50V MONO GLASS .50	CB4, CG4
23. 4001551	...	1	CAP, 1000pf 50V MONO GLASS .50	CH8
24. 4001552	...	4	CAP, .022uf 50V MONO GLASS .50	CK12, CK14-16
25. 4001553	...	138	CAP, .1uf 50V MNO/GLS .50	CB1-3, CB5-8, CC1-18, CD2,4, 8,10,12,14-22, CE3,4,6,9,14-26, CF1-9, CF11,12, 14, CG1,3,5-12 CH1-7, CH9-13, CJ2-12, CK2-11, CK13,18, CL6-31
26. 4001554	...	2	CAP, 47PF 50V MNO/GLS .50	CF13, CE5

PART NUMBER	REV	QTY	DESCRIPTION		
27.	4001556	...	13	CAP, 100pf 50V MNO/GLS .50	CD5-7, 9, 11, 13 CE7, CE8, 10-13, CF10
28.	4001562	...	1	CAP, 15uf 35V AL EL AXL .75	CH14
29.	4001570	...	1	CAP, 4.7uf 35V AL EL AXL	CG2
30.	4001571	...	5	CAP, 10uf 16V AL EL AXL	CD1,3, CE1,2, CJ1
31.	4002500	...	1	IC, 7404	ZC11
32.	4002503	...	3	IC, 74LS02	ZB4, ZF11, ZG12
33.	4002505	...	4	IC, 74LS08	ZB11, ZG5, ZG7, ZJ1
34.	4002507	...	1	IC, 74LS11	ZB12
35.	4002508	...	2	IC, 74LS20	ZD2, ZG6
36.	4002509	...	3	IC, 74LS32	ZC14, ZG8, ZG10
37.	4002510	...	2	IC, 74LS51	ZC13, ZE1
38.	4002512	...	3	IC, 74LS86	ZC6, ZC7, ZG9
39.	4002513	...	5	IC, 74LS138	ZH1, ZH8, ZH9, ZJ2, ZJ12
40.	4002516	...	8	IC, 74LS153	ZC10, ZD8, ZE3, ZE8-11, ZF2
41.	4002517	...	5	IC, 74LS161	ZD9-12, ZC3
42.	4002519	...	1	IC, 74LS175	ZG3
43.	4002521	...	1	IC, 74LS251 ** TI ONLY**	ZJ14
44.	4002522	...	4	IC, 74LS257	ZC4, ZC12, ZD4, ZD7
45.	4002524	...	1	IC, 74LS283	ZE12
46.	4002528	...	2	IC, 555	ZC14, ZC18
47.	4002529	...	1	IC, 558	ZJ13
48.	4002532	...	1	IC, 6502	ZJ8
49.	4002533	...	2	IC, 8T28	ZJ10, 11
50.	4002534	...	3	IC, 8T97	ZJ3-5
51.	4002538	...	1	IC, 74LS368	ZL1
52.	4002541	...	1	IC, 74LS27	ZG11
53.	4002555	...	2	IC, 9334	ZG14, ZH12
54.	4002556	...	1	IC, 7438	ZH13
55.	4002562	...	1	IC, 556	ZH14
56.	4002564	...	3	IC, 74LS10	ZC2, ZF12M, ZG4
57.	4002568	...	7	IC, 74LS174 ** TI OR NAT**	ZC8, ZD5,6,13 ZE13, ZG13
58.	4002571	...	8	IC, 4164-20	ZF3-10
59.	4002573	...	2	IC, 74LS399	ZC9, ZE14
60.	4002589	...	1	IC, 9333B 0144	ZH2
61.	4002590	...	1	IC, 9333B 0145	ZH4
62.	4002591	...	1	IC, 9333B 0146	ZH5
63.	4002592	...	1	IC, 9333B 0147	ZC5
64.	4002593	...	1	IC, 9333B 0148	ZH7
65.	4002595	...	4	IC, 74LS74	ZB6, ZD1, ZL13, ZF13
66.	4002610	...	1	IC, 7486	ZE5
67.	4002611	...	1	IC, 74175	ZE4
68.	4002612	...	1	IC, 74195	ZE2

PART NUMBER	REV	QTY	DESCRIPTION		
69.	4003000	...	1	IC, 6B-2012	ZH10
70.	4003500	...	2	RESNET, 1K-9	RSF1,2
71.	4003501	...	1	RESENT, 1K-7	RSL1
72.	4003502	...	1	RESENT, 2.2K-7	RSJ1
73.	4005008	...	4	INDUCTOR, FERRITE BEAD VOLT.	LL2-LL5
74.	4005009	...	2	INDUCTOR, FERRITE BEAD VIDEO	LL6-LL7
75.	4006501	...	1	DIODE, IN4148	CRB1
76.	4007000	...	2	XSTR, 2N3904	QB1, QF1
77.	4007001	...	2	XSTR, 2N4258	QE1, QE2
78.	4007002	...	1	XSTR, MPSA13	QC1
79.	4010003	...	10	SOCKET, IC 16 PIN DIP	ZF1, ZK14, ZF3-10
80.	4010011	...	6	SOCKET, IC 24 PIN DIP/DIMP	ZH4,5 ZC5, ZH2, 7,10
81.	4010012	...	1	SOCKET, IC 40 PIN DIP/DIMP	ZJ8
82.	4010018	...	1	SOCKET, POLARIZED, 16 PIN	ZD3
83.	4010520	...	8	CONN, 25/50 PIN PC EDGE	J0-7
84.	4010533	...	1	CONN, 093 HDR 5219	POWER
85.	4010550	...	2	CLIP, SHORTING	Y3-X3-X3, JH1
86.	4010567	...	1	PIN, KEYING	J6-10
87.	4010554	...	2	CONN, 20 PIN DUAL PC MT DVR CTR	JH2, JJ1
88.	4024500	...	1	CONN, PHON FEM. PC RT ANGL	JL3
89.	4027000	...	4	CONN, .100 CTR WAFER 1 PIN	JL4, X3, XY3, Y3
90.	4027001	...	2	CONN, .100 CTR WAFER 2 PIN LOCK	JB1, JC1
91.	4027006	...	3	CONN, .100 CTR WAFER 4 PIN STRAI	JE1, JH1, JL2
92.	4031001	...	1	ADHES PAD, PAUM DBL 3/8x1/2	Y1
93.	4034501	...	1	CRYSTAL, 14.318180	Y1
94.	4039022	A	1	PCB, ACE 1000/1200 64KC-32K ROM	-

MPI DISK DRIVE

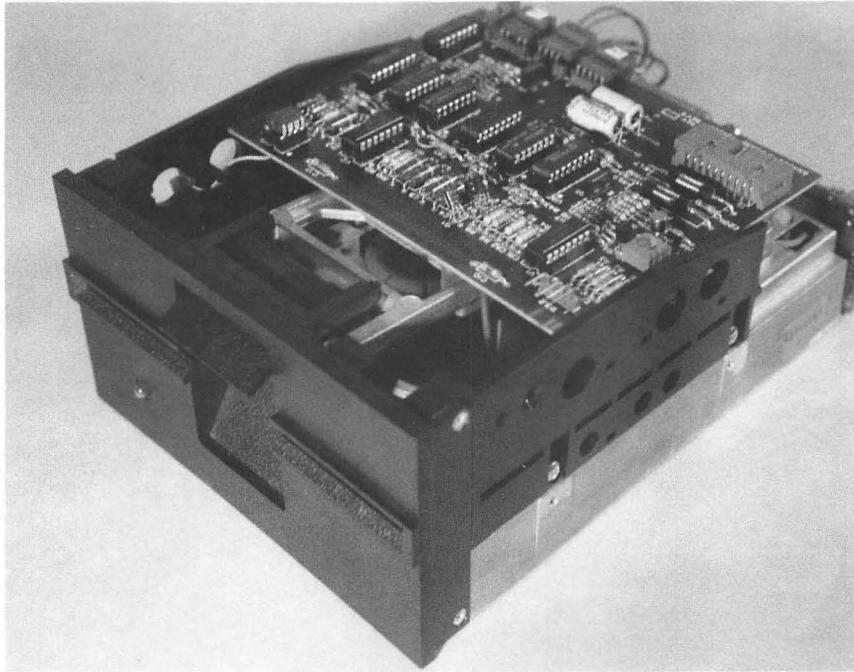

TABLE OF CONTENTS

GENERAL INFORMATION	1-1
SPECIFICATIONS	2-1
INSTALLATIONS	3-1
THEORY OF OPERATIONS	4-1
DISASSEMBLY	5-1
MAINTENANCE	6-1
PARTS LISTS	7-1

GENERAL INFORMATION

The MPI. (Micro Peripherals Inc.), 5.25" floppy disk drive was introduced in the FRANKLIN ACE 1000's and 1200's in the fall of 1983. MPI provides the mechanical assembly, model 51MS-100, with the motor drive board attached to the rear of the unit. FRANKLIN builds and installs the analog card along with the sheetmetal covers.

The MPI drive can be identified without removing it from either the 1200, 1100 tops or the ACE 10 case. When observing the drive from the front a small lever can be seen inside the right side of the disk slot. This lever will prevent the door assembly from being closed and damaging the disk if the disk is not completely inserted.

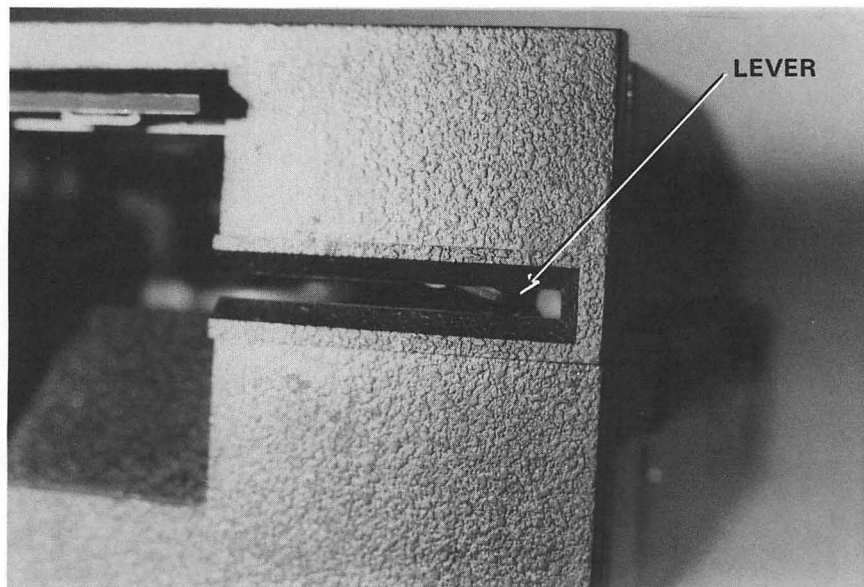

SPECIFICATIONS	
MEDIA	SINGLE-SIDED DISKETTE
BYTES PER SECTOR	256
TRACK DENSITY	48 TPI
SECTORS PER TRACK	
DOS 3.2	13
DOS 3.3	16
APPLE PASCAL	16
CP/M	16
TRACKS PER DISKETTE	35
CAPACITY	
DOS 3.2	116K BYTES
DOS 3.3	143K BYTES
APPLE PASCAL	143K BYTES
CP/M	143K BYTES
DISK SPEED	300 RPM
LATENCY	100 msec
TRACK TO TRACK ACCESS	18 msec
TRANSFER RATE	250 kbps
READ/WRITE HEAD POSITIONER	SPLIT-BAND ACTUATOR

INSTALLATION INFORMATION

The MPI disk drive can be used with the ACE 100, 1000, or 1200 computers, either as a stand alone ACE 10 or installed in a 1100 or 1200 top. When setting up a two or more drive system all drives should be the same brand, either all MPI or all Shugart. It is not recommended having two different make drives in the same system.

The drive comes equipped with a controller cable attached at one end to the drive. The other end of the cable needs to be plugged into either a controller card or motherboard depending on which type of computer is being used. All of the motherboards and all but a few very old controller cards have plugs designed to prevent improper installation of the cable. If the drive is to be plugged into an old style controller card be sure to install cable correctly to prevent damage to both the controller card and the analog card in the disk drive.

THEORY OF OPERATION

The ANALOG-M board, located on top of the mechanical drive section, receives its power source and control signals from the disk controller. Listed below are the major functions of the board and a brief description of how it is done.

READ CIRCUIT

Flux changes on the disk are picked up by the read/write coils and amplified approximately 100 times by U1. The amplified signal is then buffered by transistors Q1 and Q2 before being filtered by L1-L4. The signal then goes through differentiator U2 before going to the comparator, U3. The comparator output changes state, high or low, for each flux change. I.C.'s U7 and U8 are used to filter this output. The output of this circuit is transmitted to the controller card through connector J2-16.

WRITE CIRCUIT

Write data comes from the controller through connector J2-18 and is then buffered by U6 before going to U1. U1 takes the data signal and controls the coils in the read/write head to make flux changes on the disk. The amount of current going to the coils can be adjusted by VR1.

ERASE CIRCUIT

When writing, the nominal width of the data track is 0.013 inch. The erase circuit trims the track down to 0.012 inch. The MPI drive uses a tunnel erase head which displaces the erase poles from the read/write head. To compensate for this, the erase enable signal is delayed by IC's U9 and U10. The erase coil should be activated whenever data is being written to the disk. The erase function should clean the sides of the track being written to eliminate spillover to adjacent tracks. The erase coil is active when the signal out of U4-15 is low.

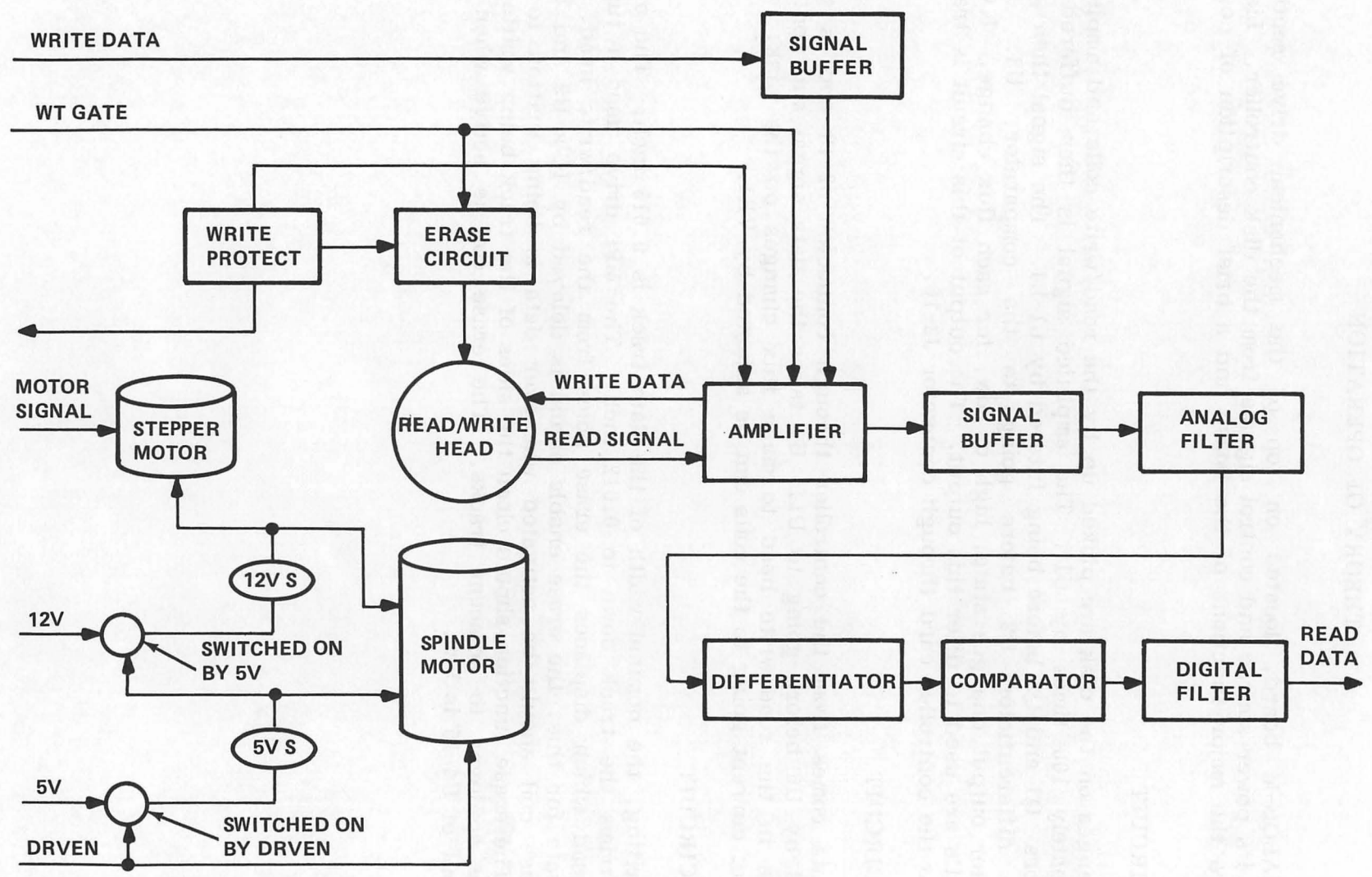

Analog-M-Board

DISASSEMBLY

The MPI disk drive assembly can be broken down into two major groups, mechanical and electrical. The electrical part consists of the analog card located on top of the drive, the remainder is the mechanical part. The small printed circuit board located on the rear of the drive is considered part of the mechanical section.

FRANKLIN does not stock or supply a complete parts inventory for the mechanical section of the drive. A few commonly used parts are available, these can be found in the parts section of this manual.

Listed below are procedures for disassembling the following:

1. Analog Card
2. Shield Assembly
3. Load Pad
4. Activity LED

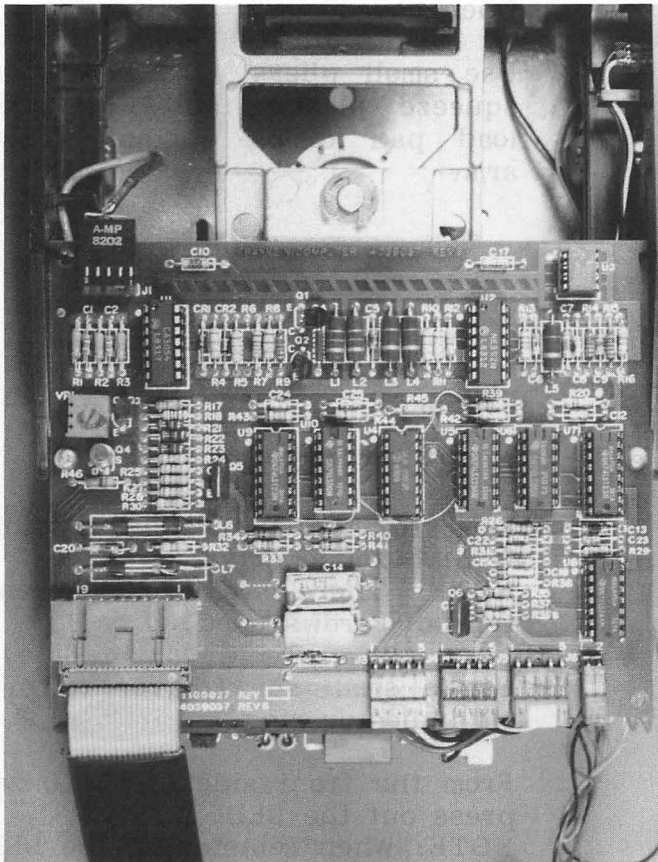

ANALOG CARD

Remove six wiring connectors.

Remove two screws at each side of board.

Slide board out towards the rear of the unit.

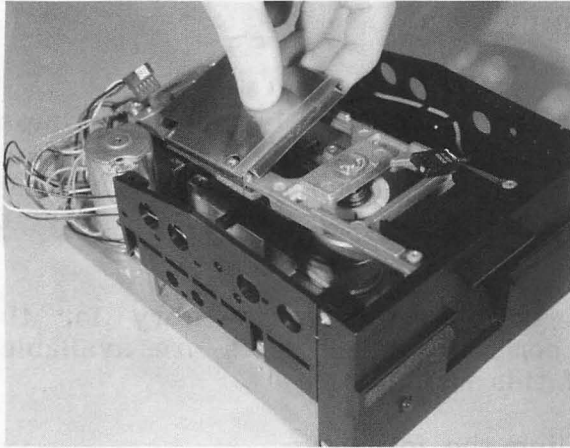

SHIELD ASSEMBLY

Press down in the center of the shield and snap off the right side of the carrier.

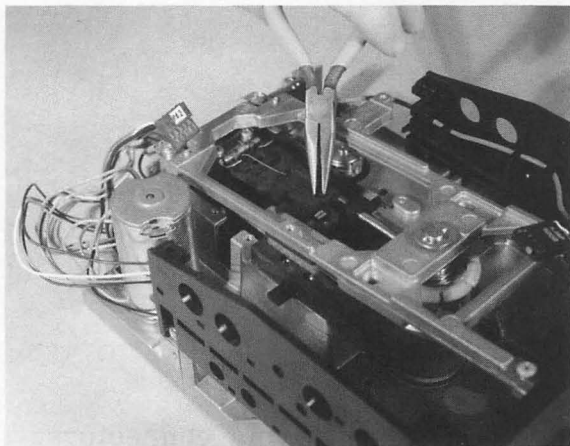

LOAD PAD

Remove analog card and shield assembly.

Open door.

Use small pliers or tweezers to squeeze plastic tabs until the load pad drops out of upper arm.

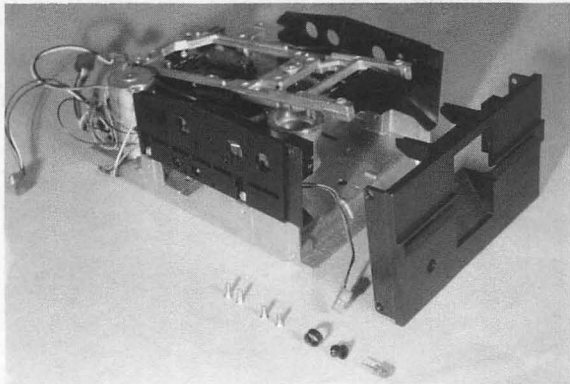

ACTIVITY LED

Remove four screws holding front bezel to drive.

NOTE: There are two different type of screws used.

Use a small screwdriver to pry off indicator ring.

From the front side of the bezel press out the LED.

NOTE: When reinstalling the LED the green wire goes on the longest LED lead.

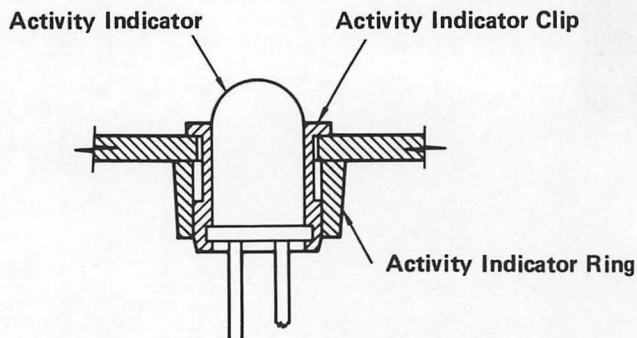

MAINTENANCE

1. PREVENTIVE MAINTENANCE
2. TEST AND ADJUSTMENT PROCEDURES
3. TROUBLE SHOOTING GUIDES
4. EXPLODED DRAWING
5. SCHEMATIC

PREVENTIVE MAINTENANCE

Periodically the read/write head and load pad should be checked for dirt and wear.

The read/write head may be cleaned using a lint-free cloth or cotton swab and either methyl alcohol or 91% isopropyl alcohol. Use a dental mirror to inspect the load pad. Lifting the load pad arm more than 1/2" may damage the arm and spring assembly, see Fig. 6-1.

CAUTION

Lubrication of the read/write head rails is not recommended by either Franklin or MPI. Tests have indicated that any lubricant used will eventually migrate to the head and cause premature failure.

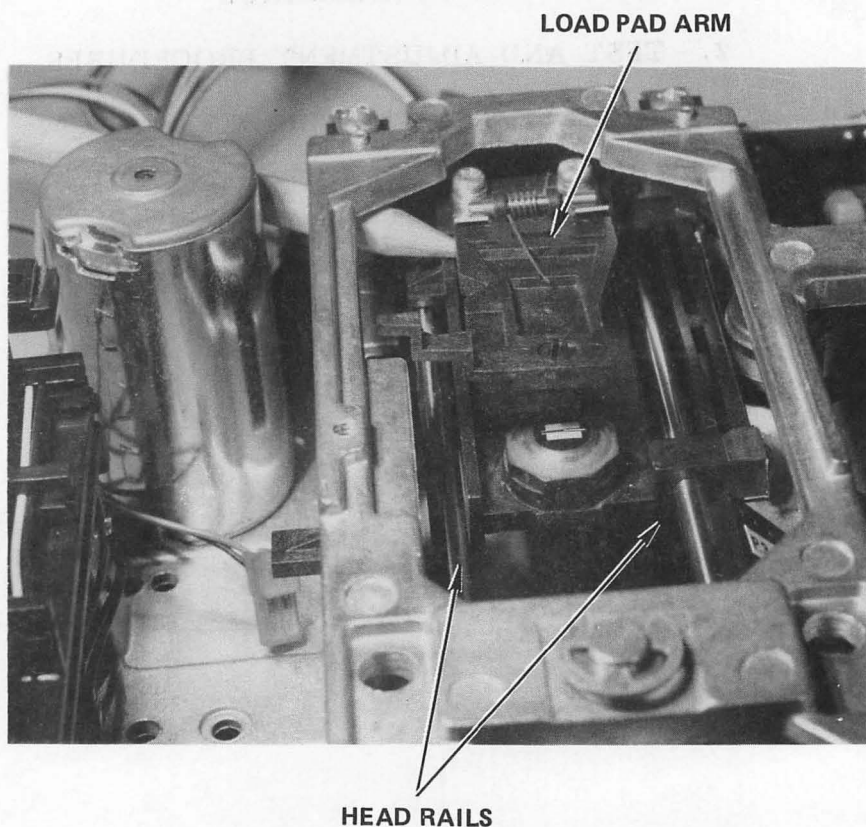

Figure 6-1

MPI DISK DRIVE

INTRODUCTION

Errors when reading or writing diskettes can be caused by a number of factors. These include incorrect operating procedures, faulty programming, damaged diskettes, airborne contaminants, electrical interference, and misaligned disk drives. This Bulletin will deal with those problems associated with mechanical and electrical misalignment of the disk drive and controller units.

EQUIPMENT REQUIRED

- A. Franklin ACE Computer and monitor.
- B. Franklin ACE 10 Disk Drive with Controller.
- C. Dual trace oscilloscope with 2 probes.
- D. Dealer Diagnostic Diskette.
- E. Alignment Diskette (Dysan 208/10 or equivalent).
- F. Blank diskette.
- G. Digital voltmeter.

SETUP

TEST	EQUIPMENT				
	SCOPE	DIGITAL VOLTMETER	INIT. DISK	DISK DYSAN	FRANKLIN DIAGNOSTIC
AZIMUTH	X			X	X
TRACK ALIGNMENT	X			X	X
TRACK 0 STOP					X
WRITE CURRENT		X			
DISK SPEED					X
R1, R2 CONTROLLER	X		X		
R/W VERIFY			X		X

AZIMUTH TEST PROCEDURES

1. Boot Dealer Diagnostics diskette and select Disk Drive Test.
2. Select the (D) Azimuth test.
3. Using a dual trace oscilloscope attach channel A probe to L3 and channel B probe to L4 on analog card. Figure 6-3.
4. Set volts/division to 20mV on both channels.
5. Invert Channel B.
6. Set time/division to 1ms.
7. Remove Diagnostics diskette and insert Dysan diskette. Three groups of four bars should appear on the screen.
8. Compare the MIDDLE group of bars on the scope to those in Figure 6-2. All of the patterns shown are acceptable EXCEPT C.
9. If the first or fourth bar is larger than either of the center two bars the azimuth is unacceptable and the drive should be replaced.

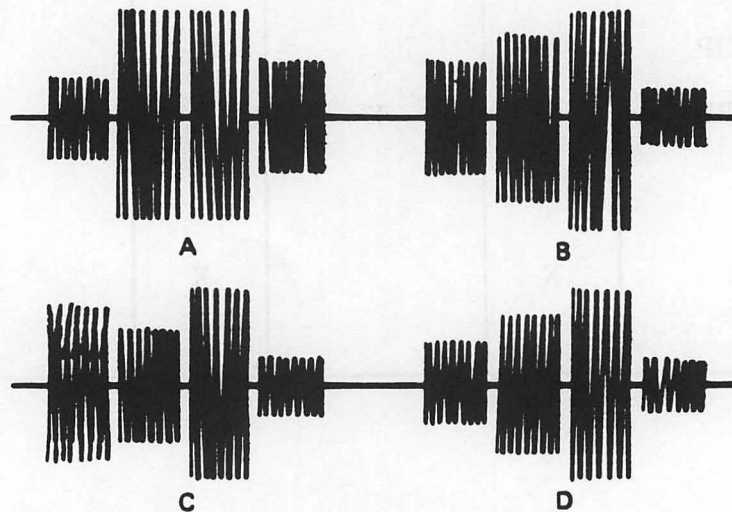

Figure 6-2.

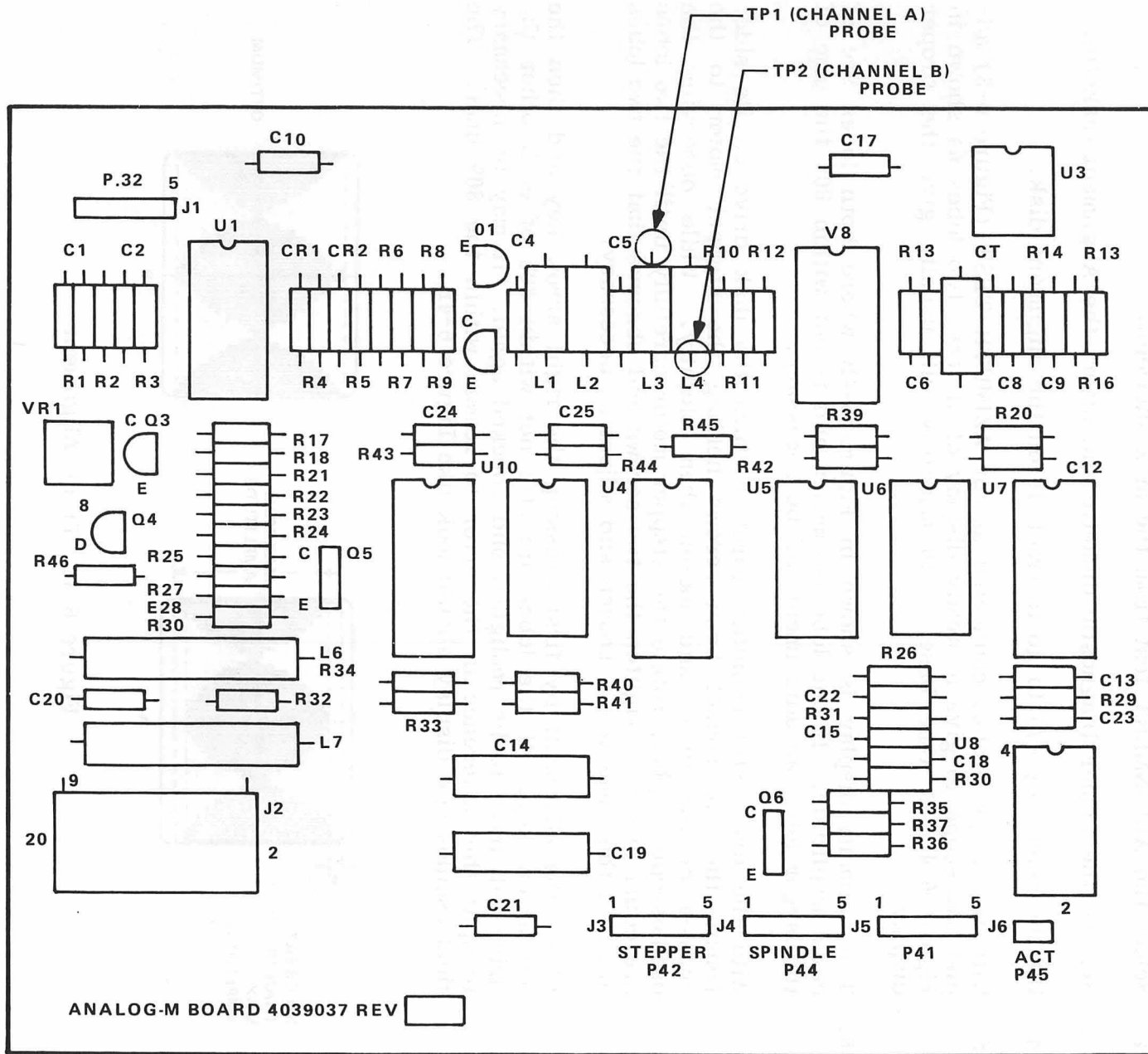

Figure 6-3. Analog-M-Board MPI Disk Drive

6-5

TRACK ALIGNMENT

1. If you have already booted the Dealer Diagnostic diskette for the Azimuth test, hit ESC key to bring up the disk submenu. If you are starting with this test you will have to boot the Dealer Diagnostic.
2. Select the ALIGNMENT test from the disk submenu.
3. Remove the Dealer Diagnostic diskette and insert the Alignment diskette.
4. Hit the slash key (/) to go to track 10 on the alignment disk.
5. With the scope probes connected as for AZIMUTH TEST (Figure 6-3) adjust the scope to give a steady display of at least two lobes as shown in Figure 6-4. A time base of 10 msec/div will usually give the proper display.
6. The optimum display is shown in Figure 6-4B where both lobes are of equal amplitude. If one lobe is smaller and is not within 80% the size of the larger lobe, an adjustment will be necessary.

With the drive still running, carefully turn the disk drive on its side. Locate the two socket head screws holding the stepper motor to the chassis of the drive and loosen them slightly. While observing the oscilloscope display, rotate the stepper motor carefully until the two lobes are equal in size. Tighten the two screws and observe that the two lobes are still the same size. Loosen and adjust as necessary.

Check the alignment by first pressing the right arrow key and then the left arrow key. If the lobes are still not within 80% of each other the drive will have to be realigned and checked again. It may be necessary to split the difference in the error to remain within the 80% limit. The final oscilloscope display should look like Figure 6-4B.

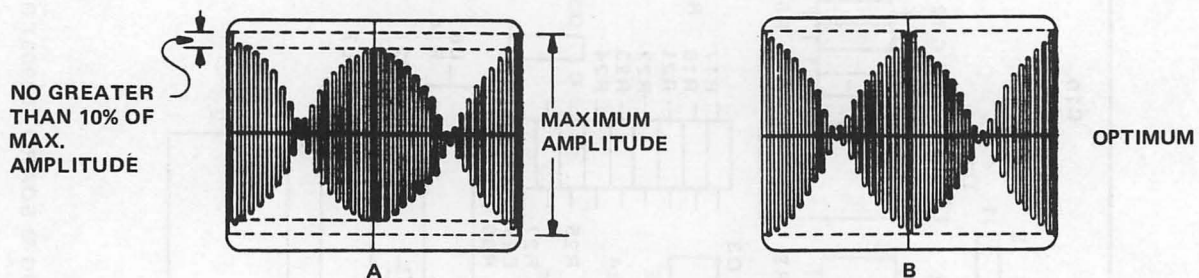

Figure 6-4. Track Alignment

TRACK 00 STOP ADJUSTMENT

1. Boot up Dealer Diagnostics and select disk test.
2. Select the ALIGNMENT test from the disk submenu.
3. Use slash key (/) to position the head at track 00. Check distance from head assembly to set screw. Figure 6-5.

There should be a distance of .010 inch. If a thickness gauge is not available turn setscrew in until it just touches the head assembly. Back set screw out 1/2 revolution.

Use slash key to move head to other tracks and back to track 00. Re-check distance.

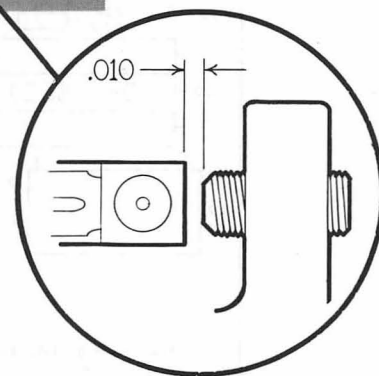
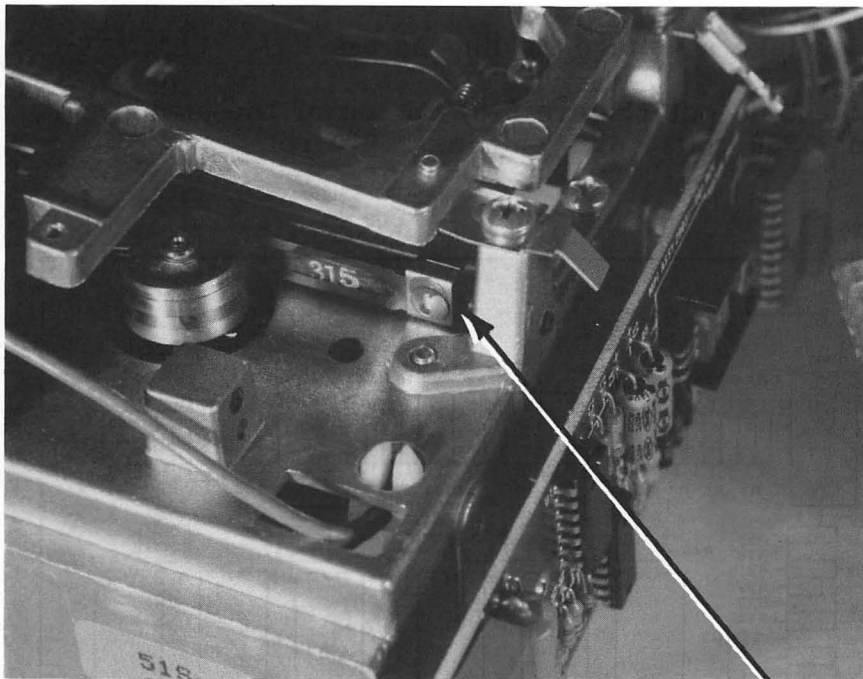

Figure 6-5. Adjustment Screw

WRITE CURRENT ADJUSTMENT

1. Adjust digital voltmeter to read 2 volts, DC scale.
2. Both 13 and 16 sector selectors should be jumpered. Figure 6-8.
3. Power up the computer, floating point basic cursor will appear at the top of the screen. (Drive will not spin as in usual operation.)
4. Key in the command - CALL 50688 - and hit return. A pound sign (#) will appear on the screen.
5. Key in - R - and hit return. The disk drive will start spinning and the pound sign and cursor will appear again.
6. Key in - AAW - and hit return. (Drive will continue spinning)
7. Use the voltmeter to take a voltage reading across R17. Figure 6-6.
8. If needed adjust the blue pot (Figure 6-6) on top of the analog card until the voltmeter reads .350 volts, plus or minus .010 volts.

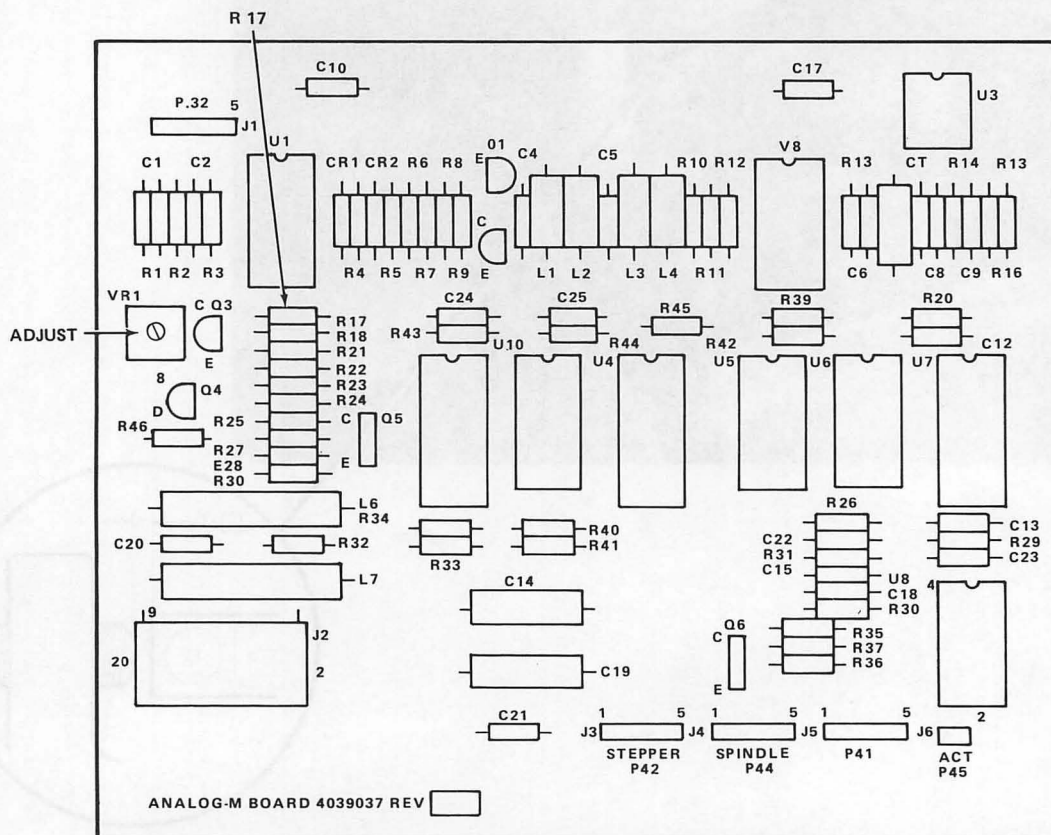

Figure 6-6. Analog-M-Board

DISK MOTOR SPEED ADJUSTMENT

The disk drive motor speed can be adjusted in two ways. The speed can be set by visually observing the timing disk on the bottom of the drive under fluorescent lighting, or it can be set with the use of the Dealer Diagnostic diskette.

A. VISUAL ADJUSTMENT

Position the drive so that the strobe disk on the bottom can be seen (you must be in an area lighted by fluorescents for this procedure to be effective). Figure 6-7.

Do not install a disk in the drive and turn on the power, this will allow the drive to spin while you make any speed checks or adjustments.

Adjust the pot on the small PC board mounted on the rear of the disk drive using a small flat screwdriver. Turn the pot until the outside band of dark lines appears motionless.

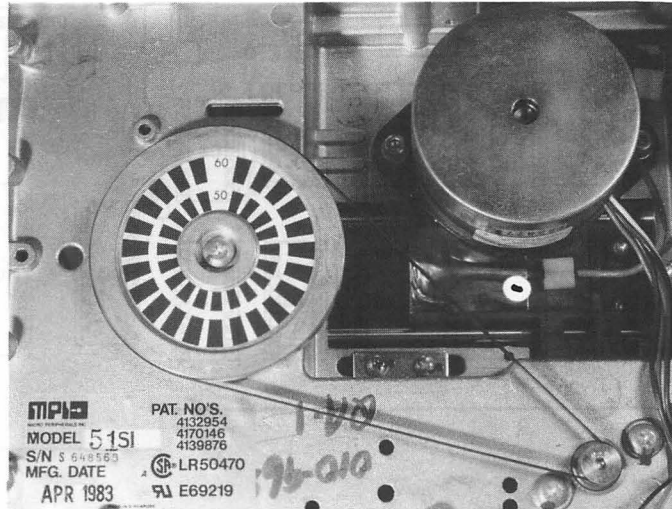

Figure 6-7. Speed Adjustment

B. DEALER DIAGNOSTIC SPEED ADJUSTMENT

Install the Dealer Diagnostic diskette in the disk drive and reset the computer to boot the diskette. The monitor screen will clear and display the diagnostic menu. Select the disk test from the menu. A secondary disk menu will then be displayed. Select the speed test from the secondary menu. The drive under test will be displayed. Adjust the pot on the rear of the disk drive for a displayed setting of 200 ms. The tolerance is + or - 1 ms.

R1, R2, CONTROLLER TEST

Connect a disk drive to the drive 1 position of the disk controller. Jumper the two left pins of J4 together (See Figure 6-8). Do not disturb the two right pins. They must also be jumpered together.

Insert initialized diskette.

Apply power to the computer. The computer will initialize and the floating point basic prompt will be displayed.

Type the following:

CALL 50688 (RETURN)
AAW (RETURN) (ESC)

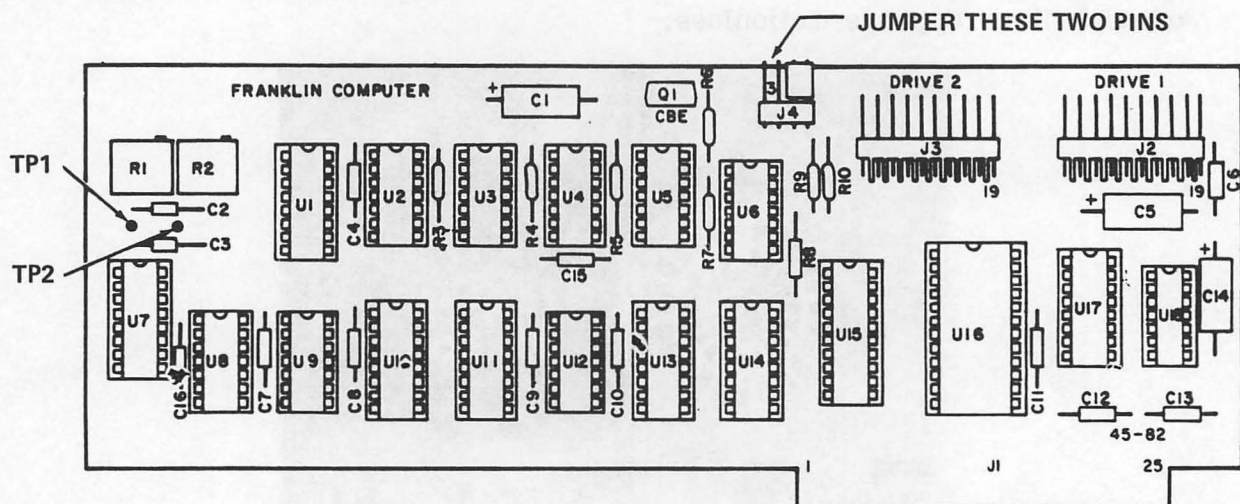

Figure 6-8. ACE 10 Disk Controller.

Connect the oscilloscope A channel probe to TP1 on the disk controller. Adjust R1 on the disk controller for a pulse width of 5.4 micro seconds.

Type the following:

99W (RETURN)

Connect the oscilloscope A channel probe to TP2 on the disk controller. Adjust R2 on the disk controller for a pulse width of 3.8 micro seconds.

11. R/W VERIFY TEST

This test should be performed after a disk drive has been adjusted to verify that it is in good working condition.

1. Install Dealer Diagnostic diskette and boot-up. Pick Disk Test (F) from menu.
2. When the Disk Diagnostics menu appears pick R/W VERIFY. (F).
3. Remove Dealer Diagnostics and insert initialized diskette.
4. Press return to start test.

If the test can make one or more passes with no errors the drive unit is in proper working condition.

TROUBLESHOOTING GUIDE -- ANALOG CARD

This guide assumes that the following items are working properly:

- A. Disk
- B. Drive Mechanical Assembly
- C. Controller
- D. Computer

SYMPTOM	LOCATION	COMPONENT
1. DEAD DRIVE CONNECTED IMPROPERLY	U5	74LS125
	U6	74LS86
	Q5	MPSU51
	C14	470uF
	C19	220uF
2. NO BOOT -- DISK OK	U2	NE592
	U3	LM311
	U4	ULN2003
3. NO BOOT -- ERASES DISK	U5	74LS125
	U6	74LS86
4. I/O ERROR	U1	CA3054
	U4	ULN2003
	U6	74LS86
5. DRIVE WORKS — BUT ACTIVITY LIGHT DOES NOT GO OFF	Q5	MPSU51

SHOWN BELOW ARE TYPICAL SCOPE PATTERNS THAT SHOULD BE OBSERVED AT THE LOCATIONS GIVEN.

SCOPE SETTINGS VOLTS/DIV .2 TIME/DIV 1us

READ CIRCUIT
STATUS

LOCATION

PATTERN

Power-on drive not activated

U1 - Pins 7 or 8



Reading data from disk
ie; HELLO PROGRAM

U1 - Pins 7 or 8



Reading data from disk
ie; HELLO PROGRAM

U2 - Pins 7 or 8



Reading data from disk
ie; HELLO PROGRAM

U6 - Pin 11



Reading data from disk
ie; HELLO PROGRAM

U5 - Pin 6



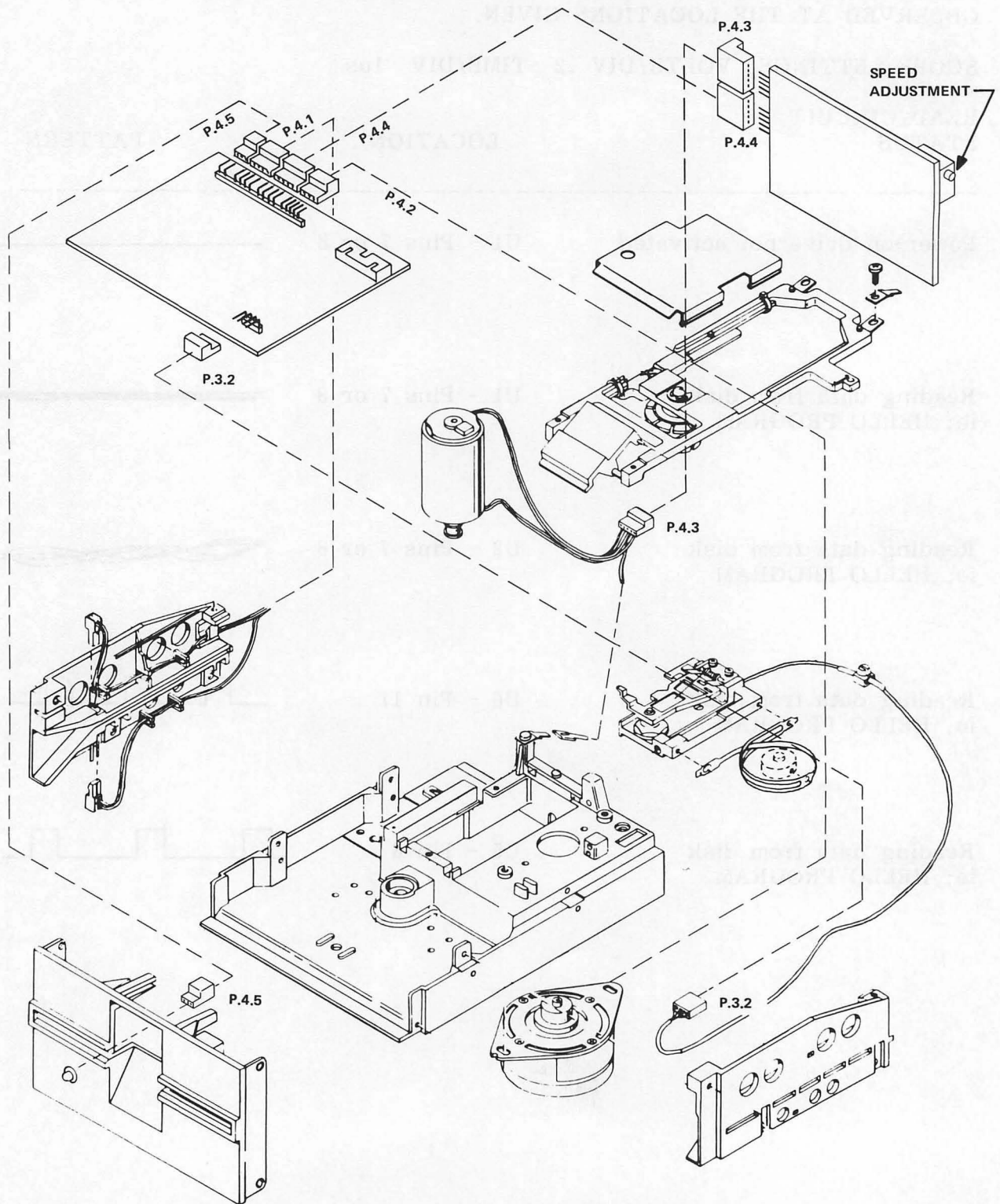

MPI Exploded View

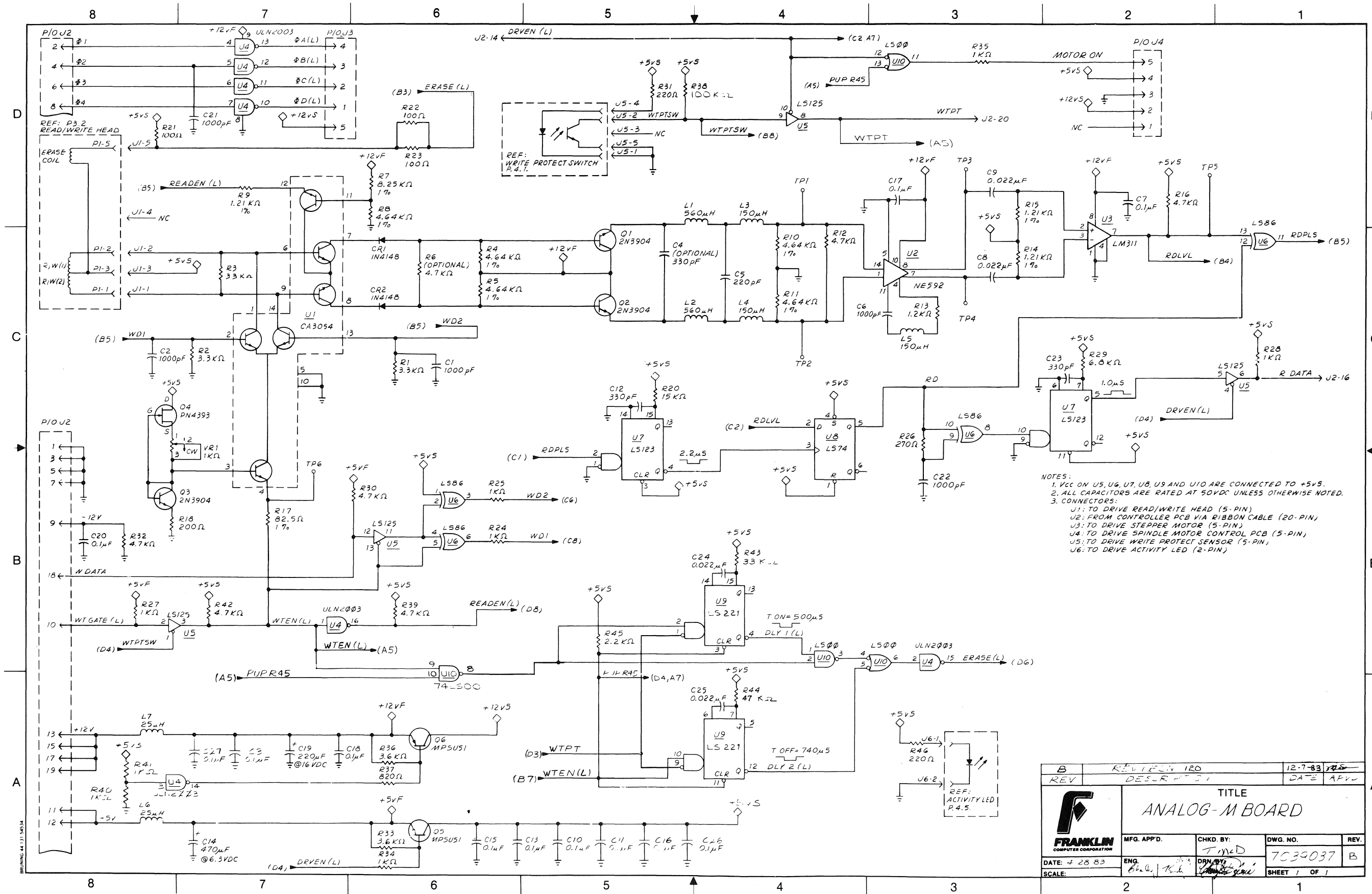

NOTES:
 1. VCC ON U5, U6, U7, U8, U9 AND U10 ARE CONNECTED TO +5V5.
 2. ALL CAPACITORS ARE RATED AT 50VDC UNLESS OTHERWISE NOTED.
 3. CONNECTORS:
 J1: TO DRIVE READ/WRITE HEAD (5-PIN)
 J2: FROM CONTROLLER PCB VIA RIBBON CABLE (20-PIN)
 J3: TO DRIVE STEPPER MOTOR (5-PIN)
 J4: TO DRIVE SPINDLE MOTOR CONTROL PCB (5-PIN)
 J5: TO DRIVE WRITE PROTECT SENSOR (5-PIN)
 J6: TO DRIVE ACTIVITY LED (2-PIN)

REV	REV 1 FCV 120	12-7-83	REV
	DESIGN # 51	DATE	APV
TITLE			
ANALOG-M BOARD			
FRANKLIN COMPUTER CORPORATION	MFG. APP'D.	CHKD. BY:	DWG. NO.
DATE: 7-28-83	ENG. [Signature]	DRN. BY: [Signature]	7539037
SCALE:			SHEET 1 OF 1

Analog-M-Board

MPI PART NUMBERS

Mechanical Assy.	4018028
Analog Card	1100027
Activity Lamp	4018036
Belt	4018037
Door Assy.	4018038
Load Pad	4018039

When ordering or installing disk drive cables note that there are three different types of cables with different Part Number.

<u>PART #</u>	<u>DESCRIPTION</u>	<u>APPLICATION</u>
4013545	27" UNSHIELDED	ACE 1200's or ACE 1100 tops 27" cable for drive closest to controller.
4013532-5	33" UNSHIELDED	ACE 1200's or ACE 1000 tops 33" cable for drive farthest from controller.
4013580	33" SHIELDED*	ALL ACE 10's

***NOTE:**

Some of the early shielded cables had just a black shielded covering. Later cables have the black covering and a ground terminal at each end. At the computer end the cable should be attached to a mounting screw for the motherboard, Fig. 7-1. Drives shipped with the grounded cable have a ground mounting terminal inside the cover, Fig. 7-2. If a shielded cable with ground terminals is to be used in a drive without a ground mounting terminal attach the ground terminal to frame of the drive, Fig. 7-3.

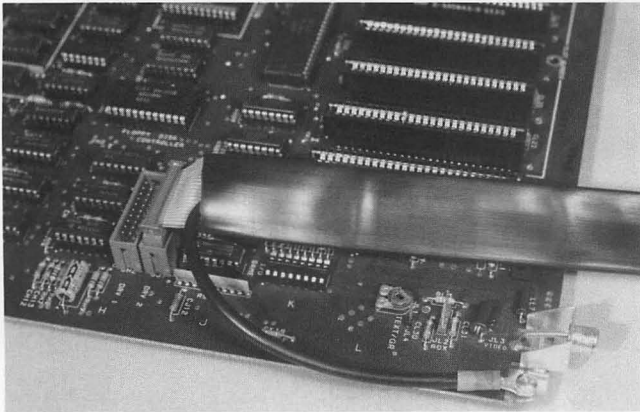

Figure 7-1
REV A Mounting

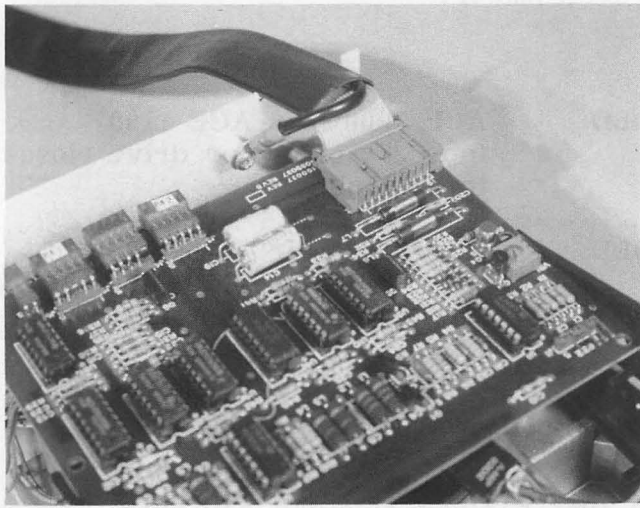

Figure 7-2
Disk Drive Cover Mounting

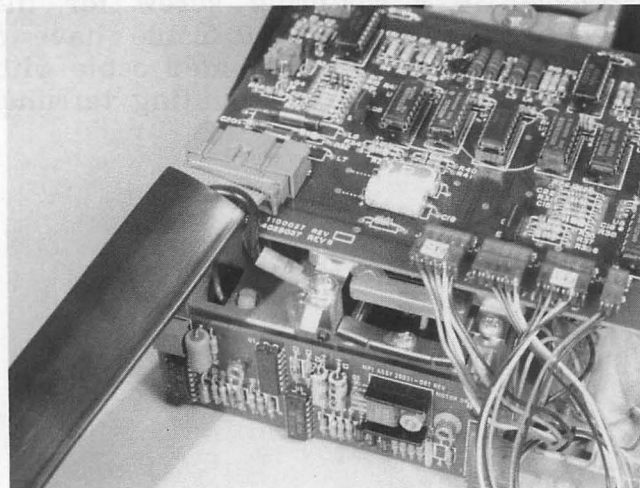

Figure 7-3
Disk Drive Frame Mounting

FRANKLIN VIDEO MONITOR

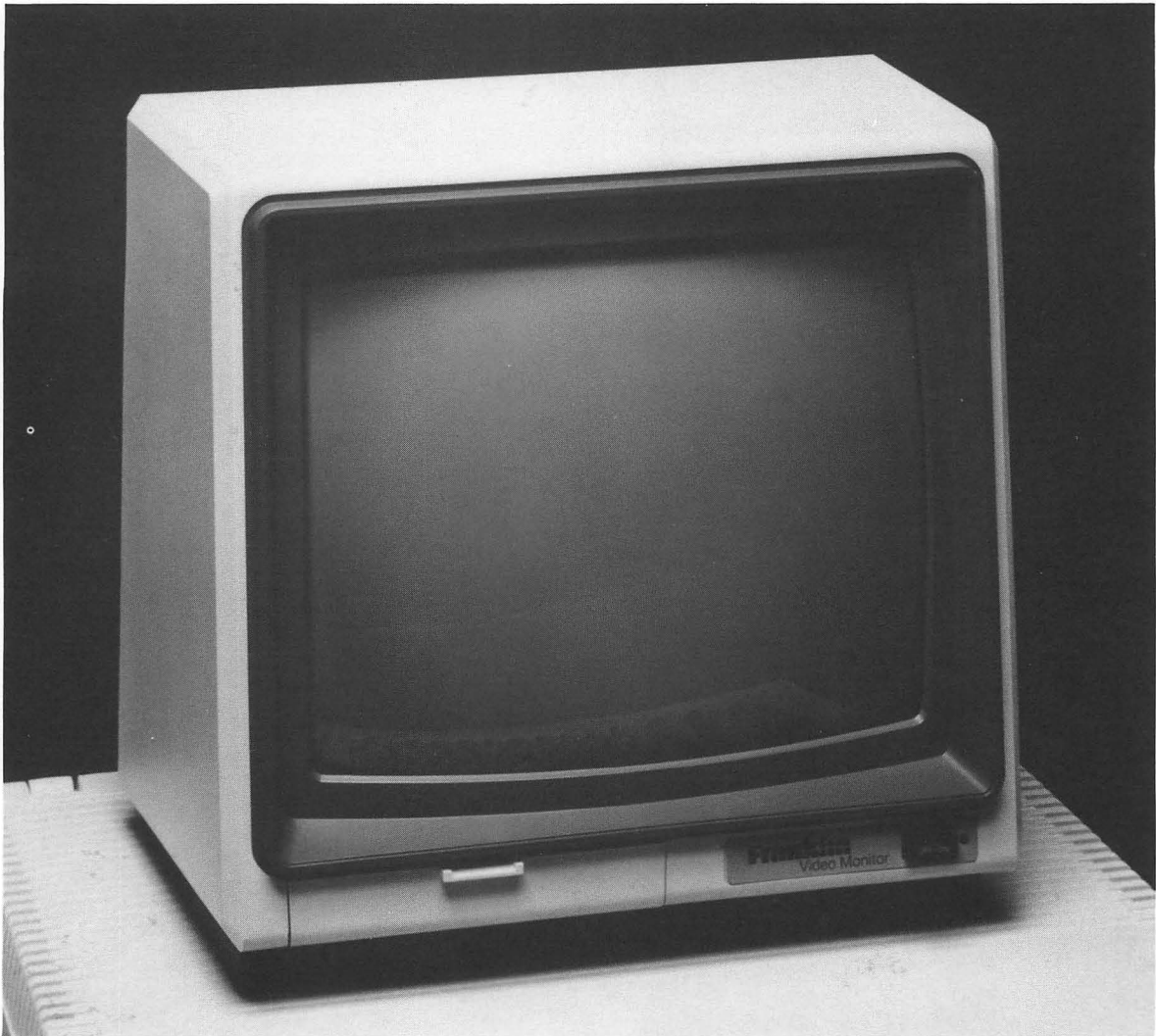

TABLE OF CONTENTS

GENERAL INFORMATION	1-1
SPECIFICATIONS	2-1
INSTALLATION	3-1
THEORY OF OPERATIONS	4-1
DISASSEMBLY	5-1
MAINTENANCE	6-1

GENERAL INFORMATION

The Franklin Video Monitor is a high-quality, high-resolution, 12 inch monochromatic CRT that can be used with any Franklin microcomputer system. It offers an outstanding combination of features, performances, and reliability.

The Franklin Video Monitor has a special premium deflection system and green phosphor CRT with a display that is remarkably easy to read and also very easy on the operator's eyes. Up to 24 lines containing 80 characters each can be displayed on the 12 inch diagonal screen.

Designed with a bandwidth greater than 15 MHz, the Franklin Video Monitor has a rise time of 30 nanoseconds which results in noticeably improved character of definition. Special DC-coupled circuitry permits the video display to retain its brightness even when the screen is full of information. In addition, special shielding allows the monitor to be placed directly atop the ACE 1000 and ACE 1200 computers.

Conveniently located exterior controls include a power switch with power-on indicator, brightness, contrast, horizontal and vertical adjustments, plus horizontal size adjustment. In addition, the Franklin Video Monitor features an external 40/80 switch that permits you to select a 40 to 80 character display width to accommodate your video format needs.

SPECIFICATIONS

CRT	12" diagonal P31 green phosphor, high-resolution video display.
Capacity	Twenty-four (24) lines of up to 80 characters in length.
Controls	Exterior controls for power, brightness, contrast, horizontal and vertical adjustments, horizontal size, selection of 40 or 80 character display.
Interface	NTSC (EIA, RS-170) composite video input.
Bandwidth	Greater than 15 MHz
Rise Time	30 nanoseconds.
Vertical Rate	54 Hz - 63 Hz
Physical Dimensions	11-3/4" high X 12-1/4" wide X 12" deep
Weight	14 pounds
Environmental	50 F to 90 F, operating -20 F to 150 F, non-operating
Power	120/220 VAC, 50/60 Hz, 26 watts

INSTALLATION

INTRODUCTION

The MONITOR should be located near an AC power source and in an area that will provide proper ventilation. There are vents located on the rear and bottom of the cabinet, permitting air flow through the cabinet. VERIFY THAT THESE VENTS ARE NOT BLOCKED

REAR PANEL

The Video In jack on the monitors uses a single conductor cable (P/N 4031507). Also located on the rear panel there is a width control and a 40/80 character switch.

DISPLAY CHECK

A quick check of the monitor display can be checked, after installation, by typing in the following program, using floating point basic.

```

10 for F = 1 to 959
20 Print "F";
30 Next F
40 GOTO 40

```

Type RUN and hit RETURN

The screen should fill up with 24 lines and 40 columns of F's with the exception of the lower right hand corner. Hit BREAK KEY to exit from this program.

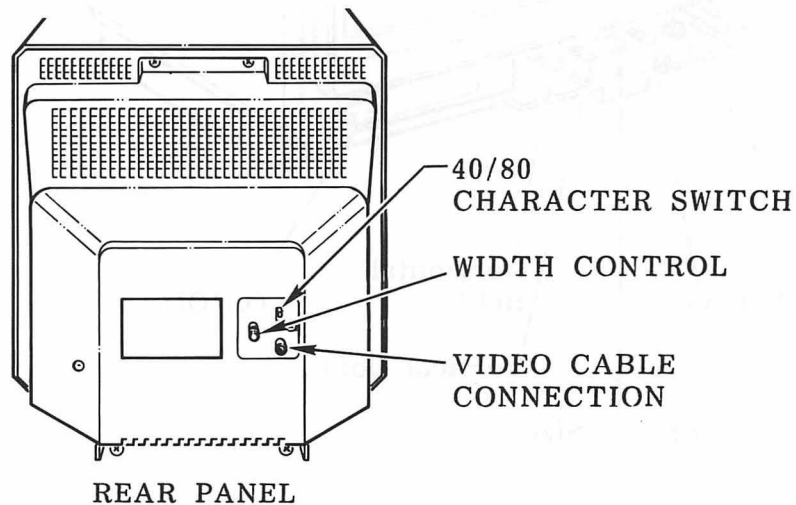

FRONT PANEL

Located on the Front Panel is the ON/OFF switch. Behind the access door are five user controls to help obtain an optimum display. These controls are:

1. Contrast
2. Black Level
3. Vertical Size
4. Vertical Hold
5. Horizontal Hold

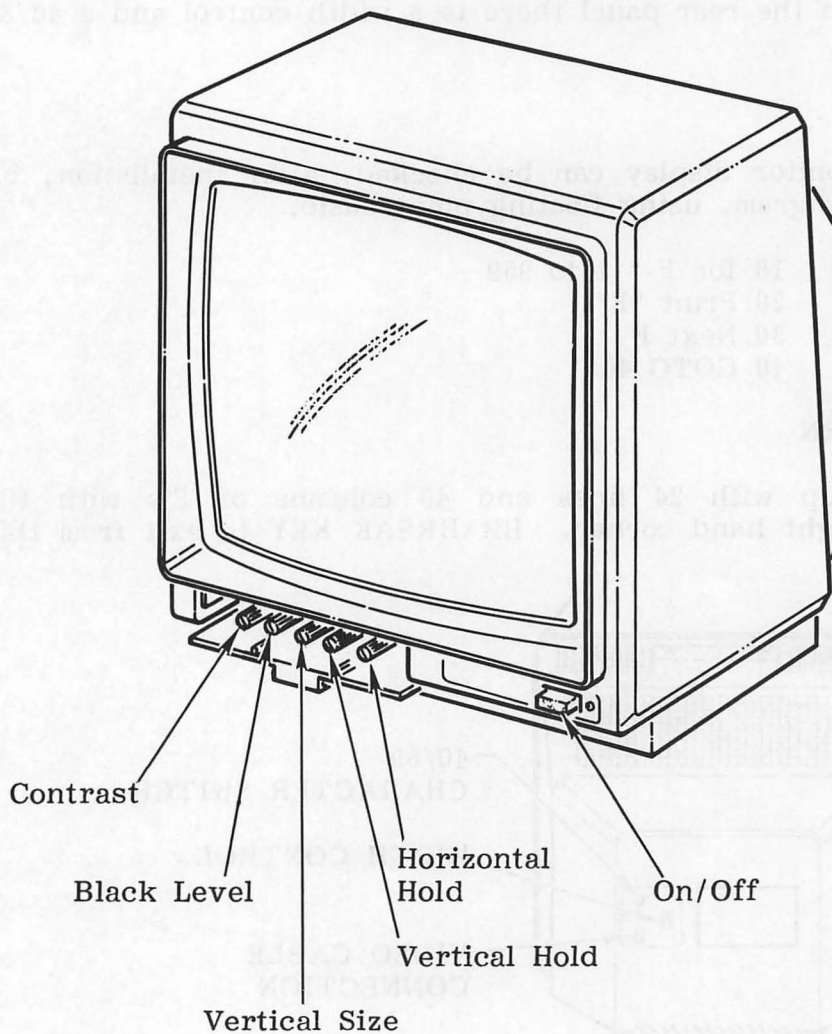

FRONT PANEL

THEORY OF OPERATIONS

Once power is applied the monitor is ready to receive and display TEXT and GRAPHIC DATA. Using the Block diagram on page 4-2, you can follow the circuit description below.

POWER SUPPLY

Source power from 120 vac enters the power supply to the primary of the step down transformer which reduces it to approximately 17-1/2 volts. Using a bridge rectifier and an RC filtering system the final output is held at 12.7 VDC. This circuit is designed in such a way as to produce a constant output even during line fluxuations on the input thereby preventing the screen from having an erratic display.

VIDEO CIRCUIT

The Video Input is configured to accept a standard RS170 composite video with a 75 OHM terminating input. The components in the preamp section are used to clamp the Video Signal to eliminate any Black Level Shifts with variation in input signal. The signal is fed to the sync AMP/SEP circuit where it is stretched and separated and sent to the output, vertical and horizontal control circuits. The signal going to the output section passes through the contrast controller. The output circuit and the beam current limiter circuit control the level of output signal to prevent unwanted fluxuations that cause periodic bright spots in the screen.

VERTICAL CIRCUIT

The vertical oscillator, amplifiers, output and blanking circuits make up the vertical circuit. The sweep circuit is a self-oscillating, DC coupled circuitry that use complimentary push pull output transistors, a driver transistor, a differential amplifier transistor and an oscillator transistor. Signals passing through these components are fed to the deflection yoke with an S correction signal to produce a linear picture on the CRT.

HORIZONTAL CIRCUIT

The horizontal processor, driver and output circuits make up the horizontal circuit. The horizontal processor (IC501) is a 221-141 which contains a phase detector, oscillator, regulator and predriver. A sync and a sawtooth waveform are fed to the differential amplifier where the output phase difference is fed to the oscillator. The resulting output sawtooth goes to the regulator where the signal is temperature compensated for stability and sent to the predriver. The resulting waveform goes to the driver and output where the "on" time is adjusted to create the desired display images.

The resulting signals from the vertical and horizontal circuits to the CRT via the deflection yoke and the Video signal directly to the CRT create the monochrome images displayed.

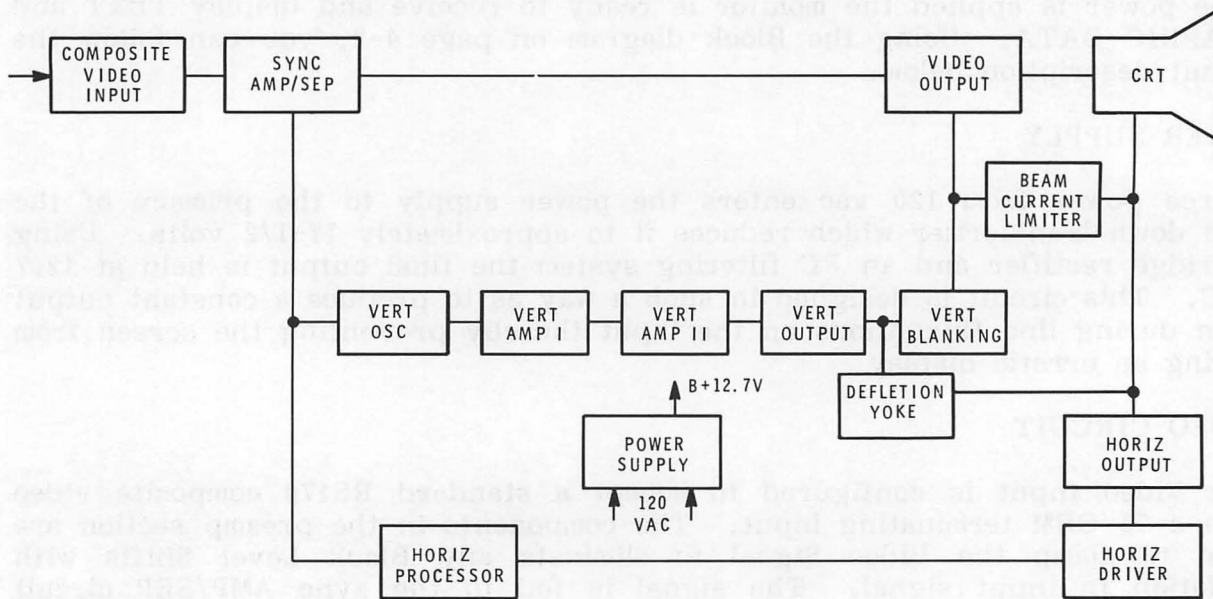

Figure 4-1. Block Diagram

DISASSEMBLY

Field level maintenance is limited to external adjustments and replacement of the two power supply fuses. The only disassembly required for this would be the removal of the back cover.

NOTE: FIRST REMOVE THE POWER CORD FROM THE POWER SOURCE.

Remove the Video cable and the six screws shown in figure 5-1. Slide panel "C" through its opening and carefully remove the back cover.

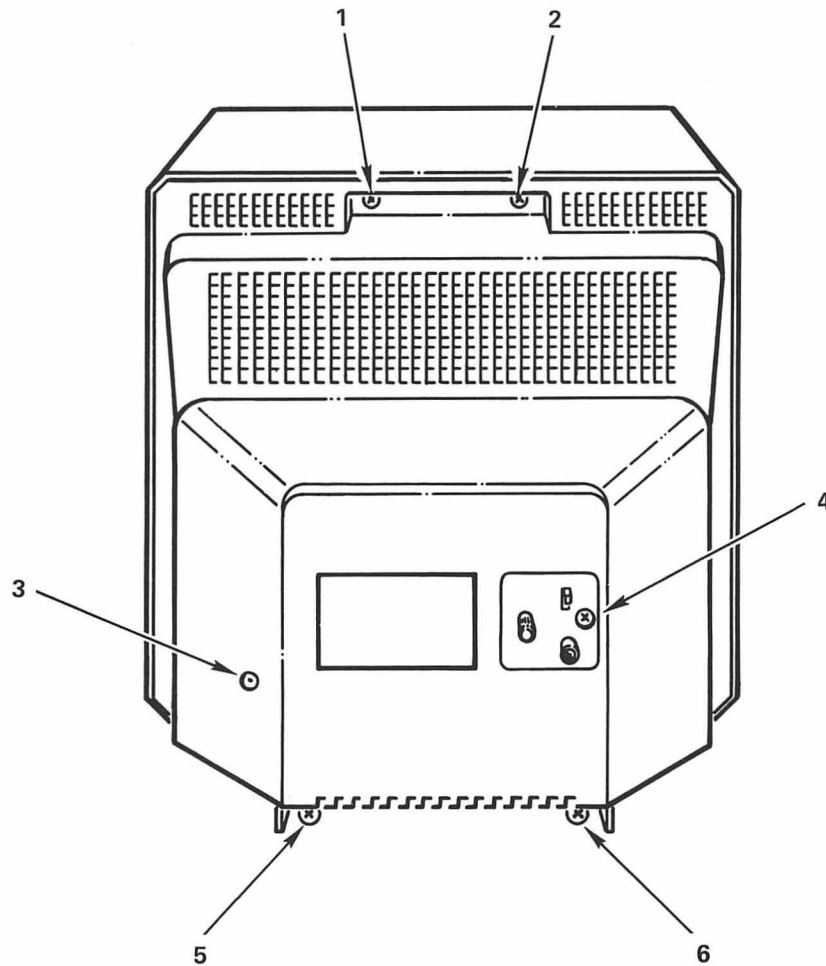

Figure 5-1

MAINTENANCE

The present level of maintenance permitted in the field is limited to the replacement of fuses FX201 and FX701, both of which are a part of the power supply circuit. If either fuse is blown the MONITOR will be completely dead. Access to the fuses is gained by removing the back cover (see Disassembly - Section 5). Figure 6-1 shows the location of the fuses and their sizes.

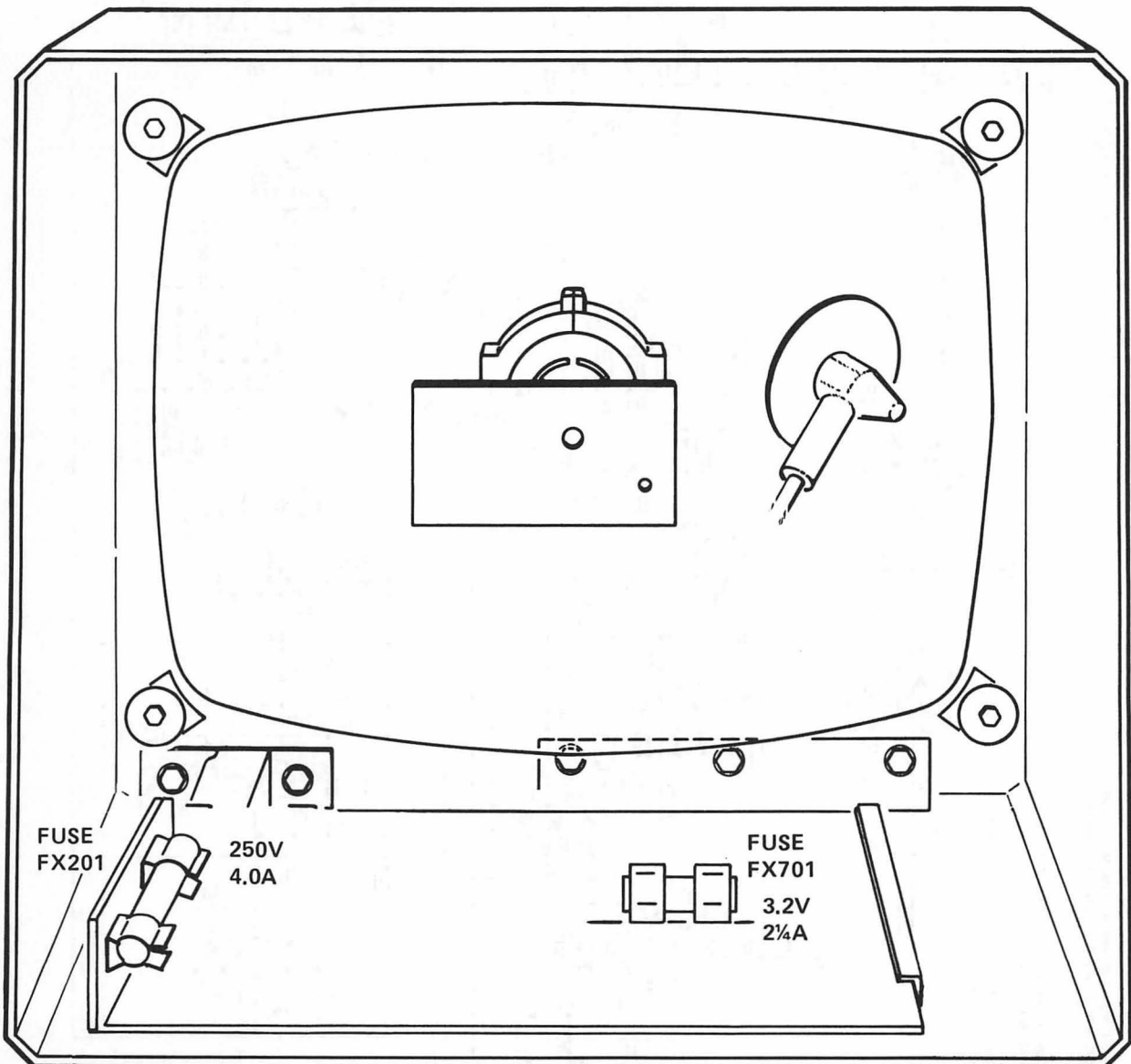

Figure 6-1

BULLETIN #: TBS-001

DATE: 01/13/84

SUBJECT: TROUBLESHOOTING GUIDE - QUICK REFERENCE

This section has been compiled to act as an aid in troubleshooting various FRANKLIN products. The information contained has been gathered from FRANKLIN's factory service centers and also from authorized FRANKLIN dealers.

Each category has a list of IC's which usually cause that problem. The IC's are listed with the most common failures first and the least common last.

INDEX

Page #

MOTHERBOARD

2-4

DISK DRIVE

5-6

DUAL I/O CARD

7

MOTHERBOARD

Sympton	Location	Component
Garbage on Screen or Wide Vertical Bars	F'5 H3, H4, H5 H10, H11 C-3 thru C-10 H-6 B6, B7 B5, B8 G2 Q5 CA8 C-11 C-14 E11, E12, E13 E14	74LS08 8T97 8T28 4116 6502 74LS257 74LS174 Eprom 222A Trans. .1 uf Cap. 7404 74LS08 74LS153 74LS283
Dead Unit, No Video Nothing	Crystal B-1 C-2 B-2 A-3 Q1 & Q2	1431818 74LS175 74LS195 74586 73LS00 4258 Trans.
No Video but Computer is Functioning	A-3 D11 thru D14 C-14 A-4 Q3 Q1 Red & Black Cable Going Between Motherboard & Colorboard.	74LS00 74LS161 74LS32 74166 3904 on B/W Motherboard 3904 on Color Board
Keyboard Problems	G-13 B6, B7 B-10 C-11 CA6 Capacitor	74LS138 74LS257 74LS74 7404 1000 pf

MOTHERBOARD (Cont'd)

Symptom	Location	Component
Hires and Lores Problems	G-14 B4, B9 H-1 B5, B8 A-9 A-10 A-11 A-13 A-8	9334, 74259 74LS194 74LS508 74LS257 74LS257 74LS151 74LS194 74LS02 16 Pin Cable Assembly
Text Problems:	A-6 U7 A-4 B-2 A-8 A-9 A-10 A-11	Eprom on B/W Board U71.0 Eprom on Colorboard 74166 74S86 16 Pin Assy. Colorboard 74LS257 74LS151 74LS194
Sync Problems	D-11 thru D-14 C-14 C-13 B-13 B-14 A-12 B-11	74LS161 74LS32 74LS51 74LS02 74LS27 74LS74 74LS08
Slot Problems	H-2 and H-12 All Ram	74LS138 4116
Machine Drops Into Monitor	G-2 thru G-10 All Ram H-6	Eproms 4116 6502
Ram Problems	E11, E12, E13 E14 All of F Row H-2 and H-12 B-5, B-8 E-2	74LS153 74LS283 74LS138 74LS174 74LS139

DISK DRIVE

Symptom	Controller		Analog	
	Location	Component	Location	Component
Dead Drive-- Connected Improperly	U6 U9 U17 U18 Q1	74LS05 74LS32 9334 74LS02 U51	U5 C14 Q5 U6 C19	74LS125 470uf U51 74LS86 220uf
Dead Drive-- Connected Properly	U6 U16	74LS05 A2 1.0		
No Boot-- Disk OK	U7 Adjust R1, R2	74LS123	U4 U3 U2	2003 LM311 NE592
No Boot--	U6	74LS05	U5 U6	74LS125 74LS86
Drive 1 Keeps Turning	U5	7400		
Both Drives Turn On Mo- mentarily, Then Drive 1 Turns On. Hit Reset and Drive 2 Turns On	U5	7400		
Drive Will Not Write	U6 U10	74LS05 74LS109	Adjust R2 U1	3054
Both Drives On	U5 U4 U17	7400 556 9334	U5	74LS125
I/O Error	U18	74LS02	U1 U4 U6	3054 2003 74LS86

DISK DRIVE (Cont'd)

Symptom	Controller		Analog	
	Location	Component	Location	Component
I/O Error When Doing INIT.	U9 U5 U10 U17	74LS32 74LS05 74LS109 9334		
Volume Mismatch When Doing INIT.	U6	74LS05		
File Cannot Be Locked	U17 U6	9334 74LS05		
File Type Mismatch When Doing Copy	U15	74LS373		
Cannot Format Destination Disk	U10 U11	74LS109 74LS174	U1	3054
Read/Write Errors	U17	9334		
Drive Works OK But Activity Light Stays On			Q5	U51

DUAL I/O CARD

Symptom	Location	Component
Board passes diagnostics but alphabet is printed incorrectly, dropping a bit.	U19	LS374
Serial port not working properly, prints garbage	Check Switch Bank #2 U12	2661
Garbage on screen	U12 U8 U1 U2	2661 74LS04 74LS32 74ALS08
Blank screen, system will not operate	U7	74LS32